

# TCG250 FLOOR GRINDER

## OPERATIONS AND MAINTENANCE MANUAL



## CONTENTS

Introduction .....	2
Declaration of Conformity.....	3
Foreword .....	6
General Information .....	6
Technical Data .....	7
Safety .....	7
Risk of Hand Arm Vibration .....	9
Media Types & Applications .....	9
Starting .....	10
Machine Operation & Dust Suppression .....	11
Shut Down .....	12
Maintenance .....	12
Checking Chart.....	14
Troubleshooting.....	16
Exploded View & Parts List.....	17
Media Types .....	20
Wiring Diagrams.....	24

## INTRODUCTION

Your new Trelawny SPT power tool will more than satisfy your expectations. It has been manufactured under stringent Trelawny SPT Quality Standards to meet superior performance criteria. You will find your new tool easy and safe to operate, and, with proper care, it will give you many years of dependable service.



### WARNING

Carefully read through these original instructions before using your new TRELAWNY power tool. Take special care to read the warnings. Your TRELAWNY power tool has many features that will make your job faster and easier. Safety, performance, and dependability have been given top priority in the development of this tool, making it easy to maintain and operate.



### ENVIRONMENTAL PROTECTION

The machine, accessories and packaging should be sorted for environmentally friendly recycling. The plastic components are labelled for categorised recycling.



### DISPOSAL

Waste products should not be disposed of with household waste. Please recycle where facilities exist. Check with your local authority or retailer for recycling advice.



## DECLARATION OF CONFORMITY

We,  
Trelawny SPT Limited of  
Trelawny SPT Ltd, CO. Indutrade Benelux BV, Anton Philipsweg 1, 1422 AL Uithoorn,  
Netherlands

Declare that under our sole responsibility for supply/manufacture of the product

Name of product

Model, Serial Number

Year of production

to which this document relates is in conformity with the provisions of the following  
Directive(s), Normative Documents and their relevant Standards:

**2006/42/EC**

**The Machinery Directive**

**2011/65/EU**

**The Restriction of Hazardous Substances Directive**

**2014/35/EU**

**Low Voltage Directive**

**EN ISO 12100 / 2010**

**EN ISO 20643:2008+A1:2012**

**EN ISO 4871:2009**

**EN 60204-1:2018**

Year and place of issue,  
2021  
Leamington Spa, England

**Adam Dickinson**  
Managing Director



DOC. Q56A/1



**DECLARATION OF CONFORMITY**

We,  
Trelawny SPT Limited of  
Trelawny House, 13 Highdown Road, Sydenham Industrial Estate, Leamington Spa,  
Warwickshire, CV311XT, United Kingdom

Declare that under our sole responsibility for supply/manufacture of the product

Name of product

Model, Serial Number

Year of production

to which this document relates is in conformity with the provisions of the following  
Directive(s), Normative Documents and their relevant Standards:

- |                            |  |
|----------------------------|--|
| <b>2006/42/EC</b>          | <b>The Machinery Directive</b>                           |
| <b>2011/65/EU</b>          | <b>The Restriction of Hazardous Substances Directive</b> |
| <b>2014/35/EU</b>          | <b>Low Voltage Directive</b>                             |
| <b>EN ISO 12100 / 2010</b> | <b>EN ISO 20643:2008+A1:2012</b>                         |
| <b>EN ISO 4871:2009</b>    | <b>EN 60204-1:2018</b>                                   |

Year and place of issue,  
2021  
Leamington Spa, England



**Adam Dickinson**  
Managing Director

DOC. Q56B/1

# DECLARATION OF CONFORMITY

<p><b>CZ</b> Prohlášení o přizpůsobení My, společnost Trelawny SPT Limited podávame daňové priznání, že výrobek a dodávka výrobku název výrobku Model, výrobní číslo Rok výroby Pro které se průkaz týká, je přizpůsobení s zásobou od následující příkazov a jejich pohotovosti: 98/37/EC Příkaz soustrojí 73/23/EC Příkaz nízkého napětí (upotřebitelné jediné do výrobku použité elektrické energie)</p>	<p><b>LT</b> ATITIKTIES DEKLARACIJA Mes, Trelawny SPT Limited Prisimindami visą atsakomybę deklaruojame, kad tiekiamas / gaminamas produktas Produkto pavadinimas Modelis, serijos numeris Pagaminimo Kuriam taikoma ši deklaracija, atitinka šių direktyvų, norminių aktų ir su jais susijusių standartų reikalavimus: 98/37/EC Įrangos direktyva 73/23/EC Žemos įtampos direktyva (taikoma tik elektriniams įrengimams)</p>
<p><b>DE</b> Übereinstimmungserklärung Wir, Trelawny SPT Limited erklären, dass unter unserer alleinigen Verantwortung für die Lieferung und Herstellung des Produktes Name des Produktes Modell, Seriennummer Jahr der Herstellung auf welches sich dieses Dokument bezieht, stimmt mit den Vorgaben der folgenden Richtlinie, normativen Dokumente und deren jeweiligen Masstabe ein: 98/37/EC Maschinenrichtlinie 73/23/EC Niederspannungsrichtlinie (nur zutreffend auf Produkte, die Strom benutzen)</p>	<p><b>MT</b> DIKJARAZZJONI TA KONFORMITA Aħna, Trelawny SPT Limited Niddikjaraw li aħna responsabbli kompletament għal provista / manifattura tal-prodott hawn 1msemmi: Isem il-Prodott Modell, Serial number Sena la 'produzzjoni Dan id-dokument magħmul għal prodott imsemmi hawn fuq, li huwa skond il-provizjonijiet imsemmija fid-dokumenti tal-klassi tax-xogħol: 98/37/EC Machinery Directive 73/23/EC Low Voltage Directive (tapplika biss għal prodotti li jaħdmu bi-elettriku)</p>
<p><b>DK</b> Erklæring om overensstemmelse Vi, Trelawny SPT Limited Erklærer hermed at under vores ene forhandling ansvar for vores forhandling/produktion af produktet Produkt navn Model, serie nummer Produktionsår For hvilket dette dokument referer, at deler i overensstemmelse med bestemmelser af følgende direktiver, normative dokumenter og deres relevante standard: 98/37/EC Machinery directive 73/23/EC Low voltage directive</p>	<p><b>NL</b> EENVOORMIGHEIDSVERKLARING Wij, Trelawny SPT Limited Verklaren dat wij de volledige verantwoordelijkheid dragen voor het leveren/fabriceren van het volgende product: Naam van het product Type, Serienummer Productiejaar En verklaren dat het product waaraan dit document verwijst eenvormig is met de voorzieningen van de volgende Richtlijn(en), Normatieve Documenten en hun relevante Standaarden: 98/37/CE MACHINERICHTLIJN 73/23/CE LAAGSPANNINGSRICHTLIJN (uitsluitend van toepassing bij producten die elektrische stroom gebruiken)</p>
<p><b>EE</b> TOOTE VASTAVUSE DEKLARATSIOON Meie, Trelawny SPT Limited Deklareerime, et vastutame järgmise varustuse/toote müügi eest Toote nimetus Mudel, Seeria number Aasta tootangu Antud dokument tõendab toote vastavust järgmistele direktiividele, normatiivaktidele ja nendega samaväärsetele standarditele: 98/37/EC MASINA DIREKTIIVID 73/23/EC MADALPINGE DIREKTIIVID (Kohandatakse vaid toodetele, mis kasutavad elektrivoolu)</p>	<p><b>PL</b> Deklaracja Zgodności My, Firma Trelawny SPT Limited, oświadczamy w naszej odpowiedzialności, że produkcja i dostawa urzadzania Nazwa produktu Model, numer seryjny Rok produkcji do którego ten dokument należy, jest zgodne z klauzulami następujących zarządzeń i ich istotnych standardów: 98/37/EC Zarządzenie mechaniczne 73/23/EC Zarządzenie niskiego napięcia elektrycznego (Zastosowanie tylko przy urządzeniach elektrycznych)</p>
<p><b>ES</b> Declaración de Conformidad Nosotros, Trelawny SPT Limited Declaramos que bajo nuestra completa responsabilidad de la fabricación/suministro del producto Nombre del Producto Modelo, No de Serie Año de producción A quien este documento se refiere, está de acuerdo con lo relacionado en la Directriz, Normativa Documentada y sus relevantes standards: 98/37/EC Directorio de Maquinaria 73/23/EC Directorio de Bajo Voltaje (Aplicable solamente a productos que funcionen con electricidad)</p>	<p><b>PT</b> DECLARAÇÃO DE CONFORMIDADE CE A empresa TRELAWNY SPT LIMITED Declara, sob sua inteira responsabilidade, que o fornecimento/fabrico do seguinte produto: Designação do produto Modelo, Número de Série Ano de produção a que esta declaração se refere, está em conformidade com o preceituado nas Directivas e Normas Comunitárias abaixo indicadas: 98/37/EC DIRECTIVA DE MÁQUINAS 73/23/EC DIRECTIVA DE BAIXA VOLTAGEM (Aplicável apenas a produtos que utilizam energia eléctrica)</p>
<p><b>FI</b> ILMOITUSVAHVISTUS Me, Trelawny SPT Limited Vahvistamme tuotteiden toimittamisesta/valmistamisesta Tuotenimi Malli, sarjanumero Valmistusvuosi Tällä todistuksella vahvistamme säädökset seuraavin ohje/ohjesin, Yleisiin papereihin ja niihin liittyvät vaatimukset: 98/37/EC KONEISTON OHJEET 73/23/EC PIENJÄNNITTE OHJEET (tarvitaan ainoastaan tuotteille jotka käyttävät sähkövoimaa)</p>	<p><b>RU</b> СВІДІТЕЛЬСТВО О СООТВЕТСТВИИ Мы, Trelawny SPT Limited Зявляем, што несем поўную адказнасць за паставку/производство ніжэказаннай прадукцыі Найменаванае издэлія Модэль, сэрійны нумэр Год выпуску на когэоу выдана наступіцье Свідэтэльства, і когэа с'я адпавядае паложэням слдуоўшэй(ых) директыв(ы), норматывівым дакумэнтам і адносіцца да іх стандартам: 98/37/EC ДИРЕКТИВА ПО МЕХАНИЗМАМ 73/23/EC ДИРЕКТИВА ПО НИЗКОВОЛЬТНОМУ ОЎРУДОВАНИЮ (распространяется только на изделия с электропитанием)</p>
<p><b>FR</b> DÉCLARATION DE CONFORMITÉ Nous, soussignés Trelawny SPT Limited déclarons que le produit sous-nommé Nom du produit Modèle et Numéro de Série Année de production et pour lequel nous prenons entière responsabilité pour sa fourniture et manufacture, est conforme aux clauses des directives suivantes documents normalisés et normes qui s'y appliquent: 98/37/EC DIRECTIVE POUR LA MACHINERIE 73/23/EC DIRECTIVE POUR BAS VOLTAGE (n'est applicable qu'aux produits utilisant l'énergie électrique)</p>	<p><b>SE</b> FÖRSÄKRAN OM ÖVERENSSTÄMMELSE Vi, TRELAWNY SPT LIMITED FÖRKÄRAR ATT VI MED ENSAMT ANSVAR ANSKAFFAT / TILLVERKAT PRODUKTEN PRODUKTNAMN MODELL och SERIE NUMMER Tillverkningsår TILL VILKEN DETTA DOKUMENT HÄNVISAR ÄR I ÖVERENSSTÄMMELSE MED FÖLJANDE DIREKTIV, NORMATIVA DOKUMENT OCH DERAS RELEVANTA STANDARDER 98/37/EC MASKINDIREKTIV 73/23/EC LÅGSTRÖMSDIREKTIV (TILLÄMPLIG PÅ ELEKTRISK DRIVNA PRODUKTER)</p>
<p><b>GR</b> ΔΗΛΩΣΗ ΠΙΣΤΟΤΗΤΑΣ Η εταιρεία Trelawny Spt Limited Δηλώνει ότι έχει τη μονδική ευθύνη ως κατασκευαστρια / προμηθευτρια του παρακάτω προϊόντος περιγραφής προϊόντος μοντέλο, αριθμός σειράς έτος παραγωγής και στο οποίο αναφέρεται αυτή η δήλωση, είναι συμβατό με τις προδιαγραφές που ορίζονται στις ακόλουθες Κοινοτικές Οδηγίες Ελεγκτικές Διατάξεις κι άλλες σχετικές προδιαγραφές 98/37/EC ΟΔΗΓΙΑ ΠΕΡΙ ΜΗΧΑΝΗΜΑΤΩΝ 73/23/EC ΟΔΗΓΙΑ ΠΕΡΙ ΧΑΜΗΛΗΣ ΤΑΣΗΣ (αφορά μόνον προϊόντα που λειτουργούν με ηλεκτρικό ρεύμα)</p>	<p><b>SI</b> IZJAVA O SKLADNOSTI Trelawny SPT Limited pod polno odgovornostjo izjavljamo, da so spodaj navedeni proizvodi, ki jih dobavljamo/proizvajamo: Ime proizvoda Model, serijska številka Leto proizvodnje na katere se ta dokument nanaša, proizvedeni v skladu z določili naslednjih direktiv, normativnih dokumentov in njihovih relevantnih standardov: 98/37/EC DIREKTIVA O STROJIH 73/23/EC DIREKTIVA O STROJIH Z NIZKO VOLTAŽO (nanaša se samo na proizvode na električni pogon)</p>
<p><b>HU</b> MEGFELELŐSÉGI NYILATKOZAT Mi, A "Trelawny SPT Limited" cég Felelősségünk tudatában kijelentjük, hogy mint a termék szállítója/gyártója Termék neve Típus, Sorozatszám Gyártási év amelyre jelen dokumentum vonatkozik, megfelel az alábbi irányelv(ek), Irányadó Dokumentumok előírásainak, és az azokat meghatározó szabványoknak: 98/37/EC GEPESSZÉTI IRÁNYELVEK 73/23/EC KISFESZÜLTÉGŰ IRÁNYELVEK (Csak az elektromos meghajtású gépeknél)</p>	<p><b>TR</b> UYGUNLUK BEYANI Trelawny SPT Limited Aşağıdaki, üretim ve tedarikinden tek bab'ına sorumlu olduđu ürünün Ürün adı Model/Seri no Üretim yılı bu belgenin ilgili olduđu aşağıdaki yönetmeliklerin, norm belgelerinin ve ilgili standartları'nın koşullarına uygun olduđunu beyan eder: 98/37/EC MAKÝNALAR YÖNETMELÝĐÝ 73/23/EC DÜĐÜK GERÝLÝM YÖNETMELÝĐÝ (Yalnız elektrikle çalypan ürünlerde geçerlidir)</p>
<p><b>IT</b> DICHIARAZIONE DI CONFORMITA La Società Trelawny SPT Limited Dichiara, sotto la propria responsabilità, che la fornitura / produzione del prodotto Nome prodotto Modello, codice Anno di produzione a cui si riferisce tale documento è conforme alle seguenti Direttive, ai documenti della Normativa ed ai relativi standard: 98/37/EC DIRETTIVA SULLE APPARECCHIATURE 73/23/EC DIRETTIVA SUL BASSO VOLTAGGIO (applicabile esclusivamente per i prodotti che utilizzano energia elettrica)</p>	

# TCG250 FLOOR GRINDER

## FOREWORD

Thank you for your purchase of the TCG250 Floor Grinder. This manual contains the necessary maintenance information for you to ensure proper operation and care for this machine. Also see the manual that is supplied by the engine manufacturer. It is essential for you to read through this manual thoroughly.

In the unlikely event that you experience problems with your TCG250 Floor Grinder, please do not hesitate to contact your local Trelawny dealer or agent. We always welcome feedback and comments from our valued customers.

## MAIN PARTS DIAGRAM

The following image of a typical electrical version TCG250, the image and operation are suitable to all 110V, 230V 400V variants.

The TCG250 comprises of a fabricated steel chassis to which all other components are mounted. Several different power units are available including electric, petrol and pneumatic options.

The power unit drives the heavy-duty cutter drum via a pulley and belt enclosed within the belt guard.

For electric models power is connected via IEC 60309 series chassis mounted plug or other suitable industrial power inlet. Deadman's button and switch must be held to allow the machine to start. The machine is started via the starter switch box. A spring-loaded 'jacking stand' is built into the machine for the purposes of taking the head out of contact with the working surface to start, or store the machine.

A separate industrial dust collector should be connected to the vacuum port).

The chassis features a location under the front cover for an optional weight.



## GENERAL INFORMATION

Before operating, performing maintenance or repairing the TCG250 Floor Grinder this manual must be read and fully understood by the operator, if in any doubt, ask your supervisor before using this equipment. Local safety regulations must be followed at all times.

Failure to follow these instructions could result in damage to the TCG250 and/or personal injury. Trelawny SPT Limited disclaims all responsibility for damage to persons or objects arising as a consequence of incorrect handling of the machine, failure to inspect the machine for damage or other faults that may influence the operation prior to starting work, or failure to follow the safety regulations listed or applicable to the job site.

This machine is primarily designed for the smoothing of concrete, marble and terrazzo surfaces. It can be used both indoors and out.

Electric models are recommended for indoor use because of the toxic exhaust gases that are produced by petrol engines.



**WARNING!** Before operating, performing maintenance or repairing the TCG250 this manual must be read and understood. If in any doubt, ask your supervisor before using this equipment.

# TECHNICAL DATA

Length x Width x Height (inc handle and wheels)	1100mm x 450mm x 980mm	43.3" x 17.7" x 38.6"		
Cutting width	254mm	10 inch		
Average depth of cut (dependent on concrete)	1 mm	0.040 inch		
<b>Electric motors</b>	<b>400v</b>	<b>230v</b>	<b>110v</b>	<b>110v 60Hz (US)</b>
Power	5.5kW (7.5hp)	2.2kW (3.0hp)	1.8kW (2.4hp)	1.1kW (1.5hp)
Voltage	400v (3ph)	230v (1ph)	110v (1ph)	110v (1ph)
Supply	11amp	16amp	32amp	15amp
Disc speed - rpm approximately	1600	1425	860	
Petrol engines: Honda GXV160	Unleaded petrol - disc speed variable dependant on throttle opening			
Electric Motor Weight	90kg	(198lbs)		
<b>5.5hp Petrol engine</b>	87kg	(192lbs)		
Working distance from wall	25mm side / 20mm front	1.0" side / 3/4" front		
Electric motor Noise LwA SWL	86.04dB (A)			
Honda Engine 5.5hp	91.5dB (A)			
Declared Noise emissions in accordance with EN ISO 15744: 2008				
	<b>Carborundum Blocks</b>	<b>Diamond Disc</b>		
Vibration (AEQ) at the Handle Bar (110v Electric)	Aeq = 2.36 m/s <sup>2</sup> (k= 0.67m/s <sup>2</sup> )	Aeq = 1.25 m/s <sup>2</sup> (k= 0.18m/s <sup>2</sup> )		
Vibration (AEQ) at the Handle Bar (230v Electric)	Aeq = 1.17 m/s <sup>2</sup> (k= 0.62m/s <sup>2</sup> )	Aeq = 0.913m/s <sup>2</sup> (k= 0.64m/s <sup>2</sup> )		
Vibration (AEQ) at the Handle Bar (400v Electric)	Aeq = 2.75 m/s <sup>2</sup> (k= 0.75m/s <sup>2</sup> )	Aeq = 2.34 m/s <sup>2</sup> (k= 0.82m/s <sup>2</sup> )		
Vibration (AEQ) at the Handle Bar (Petrol Models)	Aeq = 5.61 m/s <sup>2</sup> (k= 1.14m/s <sup>2</sup> )	Aeq = 6.35 m/s <sup>2</sup> (k= 1.59m/s <sup>2</sup> )		
(K= +40% -0%)				
Noise level measured in accordance with	EN ISO 15744: 2008			
Vibration measured in accordance with	EN ISO 28927:2012 & EN ISO 20643:2005			

Machinery Directive Information  
This tool has been designed and produced in accordance with the following directives:  
2006/42/EC Machinery Directive

If your company has any problem with our products or would like to discuss the possibility of an improvement being made to them, then please do not hesitate to contact us.  
Your comments are both important and appreciated.

## SAFETY

Wear safety boots, face mask, shatterproof glasses, helmet, gloves and any other personal protective equipment required for the working conditions. Avoid loose clothing; this may become trapped in moving parts and cause serious injury. To avoid nuisance dust, connect an industrial vacuum cleaner (minimum 3000watts or equivalent) to the 50mm (2") vacuum port situated at the rear of the machine.

Ensure that the workplace is well ventilated. Avoid operating engine-powered machines in an enclosed area, since engine exhaust gases are poisonous.

Be very careful with hot components. The exhaust and other parts of the engine are hot during operation and can remain hot for some time after shutdown.

Do not refuel the engine while the engine is hot or running, there is a very real danger from explosion – always refuel when the engine is cold, and in the open air. During transportation fasten fuel cap tightly and close fuel tap.

Do not operate electric versions in wet conditions. Caution this machine is heavy. It weighs 90kg dependent on power unit.

Do not lift this machine manually.



**WARNING!** Always observe safe-working practices at all times.

## ORGANISATIONAL MEASURES

This operating manual must always be at hand at the place of use of the machine and must be accessible to the person operating the machine. It is recommended that only persons that have received appropriate training or read this manual should operate equipment.

In addition to this operating manual, all other generally applicable legal and other mandatory regulations relevant to accident prevention and environmental protection must be observed. Such obligations may also comprise the handling of hazardous materials, provisioning and/or wearing of personal protective equipment, or road traffic regulations. This operating manual must be supplemented by instructions covering the duties involved in supervising and notifying special organizational features, such as job organization, work flows or the persons entrusted with the work. Persons entrusted with work on the machine must have read the operating manual prior to taking up work. This applies especially to persons working only occasionally on the machine, e.g. during set-up or maintenance activities.

Check - at least from time to time - whether the personnel is carrying out the work in compliance with the operating manual and paying attention to risks and safety-relevant factors. For reasons of safety, long hair must be tied back or otherwise secured, garments must be close-fitting and no jewellery - including rings - may be worn.

Severe injury may result from being caught by moving parts of the machine. Personal protective equipment must be used wherever required by the identified risk assessment or by law (e.g. safety glasses, ear protectors, safety boots, suitable safety clothing). Observe the regulations for prevention of accidents. Observe all safety precautions and warnings attached to the machine and always keep them in good and perfectly legible condition.

The personal protection equipment should consist of the following parts:

- 1) **Hard hat with ear muff**
- 2) **Visor or safety glasses**
- 3) **Dust mask**
- 4) **Protective gloves**
- 5) **Safety clothes**
- 6) **Safety boots**

In the event of safety-relevant modifications or changes in the behaviour of the machine, stop the machine immediately and report the malfunction to the competent authority/person. Do not remove or make inoperative any safety devices the machine is equipped with.

Never make any modifications, additions or conversions which might affect safety. This also applies to the installation and adjustment of safety devices as well as to welding and cutting work on supporting structures.

Damaged or worn parts of the product must be replaced immediately. Use genuine Trelawny spare parts only. All spare parts and tools must comply with the technical requirements specified by the manufacturer/distributor. Adhere to the legally prescribed preventive maintenance and inspection intervals or those specified in this operating manual.

All maintenance and repair activities must be performed by qualified personnel using suitable tools and other suitable workshop equipment. Observe the fire alarm and fire fighting measures. The personnel must be made familiar with the location and handling of fire extinguishers.



Wear Safety Glasses



Wear Hard Hat



Wear Safety Boots



Wear Protective Gloves



Wear Safety Clothes



Wear Dust Protection



Wear Ear Protection



Read Ops Manual

# RISK OF HAND-ARM VIBRATION INJURY

These tools may cause Hand-arm Vibration Syndrome injury if their use is not adequately managed. We advise you to carry out a risk assessment and to implement measures such as; limiting exposure time [i.e. actual trigger time, not total time at work], job rotation, ensuring the tools are used correctly, ensuring the tools are maintained according to our recommendations, and ensuring that the operators wear personal protective equipment [PPE] particularly gloves and clothing to keep them warm. Employers should consider setting up a programme of health surveillance to establish a benchmark for each operator and to detect any early symptoms of vibration injury.

**We are not aware of any PPE that provides protection against vibration injury by attenuating vibration emissions. See 'Specifications' section for vibration emission data. Further advice is available from our Technical Department.**

**We strongly advise you to visit the Health & Safety Executive website** <http://www.hse.gov.uk/vibration>  
This site provides excellent advice and information on HAV and currently, includes a Hand-arm Vibration Exposure Calculator that is easy to use to work out the daily vibration exposure for each of your operators.

# MEDIA TYPES AND APPLICATIONS

Trelawny TCG grinders can be fitted with a range of different grinding tool options suitable for preparation of a range of substrates and surface preparation applications.

Diamond Tooling is available in two ranges.

Replaceable 250mm Diamond grinding discs are available in 3 bonds (soft, medium, hard), in 10,16 and 20 segment options.



Quick Release (QR) tooling offers a wider range of application solutions.



Diamond Disc (D suffix) machines are fitted with a 20 segment medium bond replaceable grinding disc for general grinding applications.

QR (QR suffix) machines are supplied fitted with a "tool holding plate". QR tooling is supplied separately.

Additionally Trelawny classic Grinding blocks and accessories can be Retrofitted to any TCG Grinder.



## PRE-START CHECK (DAILY)

### ALL VERSIONS

Check all bolts and screws for tightness. Ensure that all fittings are secure. Check the drive belts for correct tightness. There should normally be approximately 13mm (1/2") of free play when the belt is depressed in the middle position between the two pulleys. To check and set the belt tension, refer to the Belt installation & Adjustment section.

### PETROL MODELS

Check engine oil level. If the engine oil level is low, refill with the relevant motor oil.

Check there is sufficient fuel in the fuel tank.

Check the air cleaner elements are clean and in good condition. Clean or replace the elements if necessary.

Read the engine manufacturers operating and maintenance manual for detailed servicing instructions

### ELECTRIC MODELS

Check that the power supply on site is suitable for the equipment.

Ensure all extension cables are fully uncoiled and never left wrapped around cable reels or tied in loops.

Check all cable connections are secure and not damaged.

Read the 'Power supply' section for specific cable and power configurations.

**CAUTION!** Beware of poisonous fumes coming from engine versions. Start and operate only in well-ventilated areas.

## ELECTIC POWER SUPPLY

### ALL ELECTRIC MODELS

The Tcg250 is supplied with a specially commissioned electric motors and starter box assembly. Each unit is fully tested and have been calibrated and set according to the manufactures specifications. In the event of malfunction on a new machine, the owner should first check that the power supply on site is suitable and adequate. All cables should be fully uncoiled and never left wrapped around cable reels or tied in loops. The starter box is fitted with a safety feature to protect the motor and from damage. The starter boxes are pre-set and under no circumstances should they be tampered with, stripped down or adjusted, otherwise it will invalidate the warranty. The starter control box must only be accessed by a fully trained person or electrically qualified engineer.

### 110V Models

Use a centre tap transformer with a continuous rated output of 5.0KVA. Do not add an extension lead to the transformer input. The motor requires the minimum of a 32amp, 110v power supply.

To avoid Voltage drop Trelawny recommends a maximum cable length of 20m with a core wire size of 4mm<sup>2</sup> cross sectional area. The use of 2.5mm<sup>2</sup> for 110v machines is not recommended and can cause operating problems, particularly in conjunction with poor supplies, where excessive voltage drops will be encountered and damage to the machine may occur.

### 230v Models

Take particular care when using 230v Machines, ensure that the electrical supply is earthed and that breakers and fuses are correct for the loading. The 230v motor requires the minimum of a 13amp, 220v power supply. Always use the shortest possible length of extension cable.

To avoid Voltage drop Trelawny recommends a maximum cable length of 40m with a core wire size of 4mm<sup>2</sup> cross sectional area.

### 400v Models

Take particular care when using 400v Machines, ensure that the electrical supply is earthed and that breakers and fuses are correct for the loading. The 400v motor requires the minimum of a 10amp, 380v power supply. Always use the shortest possible length of extension cable.

To avoid Voltage drop Trelawny recommends a maximum cable length of 40m with a core wire size of 4mm<sup>2</sup> cross sectional area.

### TRELAWNY APPROVED EXTENSION CABLES

Part Code	Description
669.3121	20m 110v 32amp power cable with sockets
669.3122	20m 230v 16amp power cable with sockets
669.3124	20m 400v 16amp power cable with sockets



**BE CAREFUL!** The exhaust and other engine parts are hot during and for some time after operation. Do not touch them.

# STARTING WORK

## Machines fitted with electric motors

Inspect the supply cable; check that no damage has been caused to the outer casing and that there are no exposed or loose wires. Obtain the assistance of an electrician if a fault is found. Do not use the machine until it has been rectified. Check that the cable is not running across sharp or jagged edges and that it is not in contact with any liquid.

It is recommended that the 'jacking stand' is employed to start the machine. To engage the stand, tilt the machine to lift the grinding head(s) and, whilst tilted, depress the foot pedal (at the rear of the machine, between the wheels), keeping it depressed whilst lowering the machine back towards its normal working position. This action will result in the front of the machine appearing slightly raised. To disengage the stand ready for use, tilt the machine rearwards slightly and the stand will be heard to retract. The grinding head(s) will now be engaged with the working surface.

Turn red isolator knob to the "ON" position. The machine is now energised. To start the machine, depress button and keep depressed. As soon as the button is released, the machine will stop.

## VOLTAGE INDICATOR (2025+ Models)

A consistent and adequate power supply is critical for the reliable operation of electric tools and machinery. Insufficient voltage can lead to sub-par performance and potentially cause costly damage to motors and electrical components. All 110, 230v & 400v models produced from January 2025 (Serial Number T2500000+) are fitted with a digital voltmeter as standard.

The indicator is activated when the isolator switch is turned to the 'on' position.

Always check the supply voltage before powering the motor. If you identify a higher or lower than required voltage level, turn off the machine and check the power source.

Long power cable runs can potentially cause voltage drop. Refer to the 'Electric power Supply' section for further information.

## VOLTAGE TOLERANCES\*

Actual supply voltage can vary from region to region. Trelawny recommends the following voltage brackets for its equipment:  
110v - 99v minimum - 121v maximum  
230v - 207v minimum- 253v maximum  
400v - 357v minimum- 440v maximum

\*NOTE: These are Approximate voltage ranges, if the number displayed is substantially higher or lower than either end of the voltage range detailed above, then please check your power supply.

## Machines fitted with petrol engines

Check that there is sufficient fuel in the fuel tank. (See manufacturer's hand book for type.) Check that the engine oil level is correct. (See pre-start check.) Ensure that the machine is started on a level surface. Open the engine fuel tap. For cold engine starting, the 5.5hp engines have an automatic choke, apply full throttle to operate. Set the start switch to the "on" position on Honda supplied engines. To engage the stand, tilt the machine to lift the grinding head(s) and, whilst tilted, depress the foot pedal (at the rear of the machine, between the wheels), keeping it depressed whilst lowering the machine back towards its normal working position. This action will result in the front of the machine appearing slightly raised. To disengage the stand ready for use, tilt the machine rearwards slightly and the stand will be heard to retract. The grinding head(s) will now be engaged with the working surface.

Check that the machine has been raised on its stand. Press the Hold to Run button. Pull the recoil starter cord handle. After the engine starts, move the throttle lever towards the idle/tick-over position until the engine runs smoothly. After a minute or two reduce to a quarter open throttle setting and warm up the engine for a further 2-3 minutes before setting to tick over. The warm up procedure is particularly important during cold weather.

# MACHINE OPERATION & DUST SUPPRESSION

(Please refer to manual handling recommendations when lifting.) Connect a suitable commercial vacuum which has been designed for the collection of concrete dust and possibly toxic paint particles, or for use in the pharmaceutical or food industries, Trelawny can supply special HEPA filtered vacuums which are suitable for these applications. Or if suitable for the area being worked, connect a water hose to the supplied connection at the rear of the machine.

On engine-powered machines, once the engine has reached operating temperature and you are ready to start work, set the throttle lever to the full throttle position, pull back on the handle bars to retract the machines stand and slowly lower the disc to the surface. T

The machine may oscillate slightly during use, which is normal. Move the machine slowly backwards and forwards, slightly swinging the grinding head right and left; this will ensure that a uniform finish is achieved.

Complete a small area noting the performance; on engine versions reduce the throttle to tick over and release the Hold to Run button. Then on both engine and electric motor versions release the 'hold to run' button to stop the machine, inspect the finish produced. If necessary change the grade of grinding tools and recheck performance and surface finish.

## SHUT DOWN

On electric-powered machines, simply release the Hold to Run button. On engine-powered machines, move the engine's throttle lever to the slow speed position. (This avoids the engine becoming washed internally by neat fuel if switched off from high engine revolutions.) Release the Hold to Run button and on Honda engines, switch off the engine's start switch.

On both electric and engine-powered machines, use the stand to raise the disc off the ground to prevent any built up heat deforming the rubber coupling if it is left under load whilst hot and stationary. The machine can be stored whilst on its stand.

After the engine or motor has completely cooled, clean off

any concrete dust from external components and remove any heavy build up of concrete dust from inside the front dust skirt, (see start of "Grinding Tool Replacement" section for safe method of gaining access to inside of front dust skirt). Take care when using hoses or pressure washers and clean within the dust skirt area only.

Do not to allow water to be directed at or splashed onto the engine, electric motor or any electrical components. Once clean and dry, cover the machine to protect it and store the grinder in a dry place.



**IMPORTANT!** Close the engine fuel tap

## MACHINE STORAGE

### Long period storage: over 3 months

Clean outside of machine, inspect the grinding tools for wear; replace any worn parts as required.

Remove any build up of material from inside of grinding disc area following step in start of "Grinding Tool Replacement" Section. Cover the machine to protect it. Store the machine in a dry place.

## OPERATING RANGE

This machine is specifically produced for use on concrete. Do not modify, add components to or retrofit the unit in a way which could affect its safety and do not use non-official accessories. This is not allowed. A full range of genuine parts are available to purchase. Do not use machine in water.

## MAINTENANCE

### Belt Installation & Adjustment

#### Removal

Remove the top cover by unscrewing the two 8mm bolts either side of the chassis. Loosen the engine/motor mounting plate bolts and slide the engine/motor forward. Slide the belt off the drive pulley and then remove it from the engine/motor pulley.

#### Installation

Slide the new belt onto the engine/motor pulley first, locating the belt in the pulley's teeth. Then slide onto into the teeth of the drive pulleys.

Slide the engine/motor backwards until the slack in the belt is taken up, gently nip the four bolts and ensure the slack in the belt is correct (see note below). If the tension needs adjusting move the motor mounting plate in the desired direction until the correct tension is achieved. (see P.10, Pre-Start Check for

detail) Tighten all engine/motor mounting plate bolts fully, refit the top cover and tighten the 8mm bolts.

### Drive system maintenance

The drive system on the TCG250 is virtually maintenance free and will give a long service life without attention providing the belt tension is set correctly.

The belt may need changing occasionally, the bearings (29) will require greasing after any lay up period and/or every 6 months or occasionally during heavy use.



**IMPORTANT!** Normal slack should be approximately 13mm (1/2") when the belts are depressed in the middle position between the engine pulley and driveshaft pulley.

# MAINTENANCE

## Grinding Tool Replacement

**Switch off the engine-powered versions and allow the engine to cool completely, disconnect electric-motorpowered versions from its power supply.**

Place the machine on a flat and level surface. Raise the front skirt by loosening the four 10mm guard retaining bolts on either side of the machine and slide the guard up to the top of the slots, tighten the bolts temporarily.

## Electric Machines

Tilt the machine backwards to rest on its handle bar. Place a heavy object (10kg sand bag, etc.) across the upper part of the handle bar or tie down for additional security. It is not recommended that petrol/gasoline-powered models are tilted back on their handles, this may cause leakage of fuel and is therefore a hazardous operation.

## For QR tools -

Removal - Firmly hold the QR tool and using a plastic faced hammer give the outside edge of the tool a sharp tap to release the tool from its beveled retainer on the tool holding plate. Dispose of the used item according to local legislation.

First fitment and replacement - the QR tool holding plate features integrated magnets which help locate and secure the QR tools. Offer up each tool and firmly slide to locate the beveled tool edges into each location on the tool holding plate. For added security while fitting give each tool a firm tap with a plastic faced hammer. In operation the centrifugal force of the grinding head will keep the QR tools securely in place. The QR tool holding plate can hold a maximum of 6 QR tools. A half set of 3 QR tools can be used to increase grinding pressure for specific applications. If using Resin polishing tools a maximum of 3 Velcro polishing tool adaptors (350.5666) can be fitted. Only ever fit and operate the machine using a full set (6pcs Metal QR tools) or half set 3 pcs (Metal QR tools or Resin tools) fitted on alternate locations.

## To replace Diamond Grinding plates and remove/replace QR tool holding plate

Remove the four countersunk M12 screws from the disc, ensuring that the disc is supported as the last two are removed. The disc now will come away from the drive plate. Dispose of the used item according to local legislation. Offer the new disc up to the drive plate and align the holes using the central locating spigot. A sharp tap with a plastic faced hammer will help locate the plate. Loosely fit the four bolts and then tighten in a diagonal sequence to 40lb/ft.

## To replace Grinding Blocks

Take note how the grinding blocks and wedges have been assembled, using a suitable wooden drift, knock out the grinding block, not the wooden wedge. Dispose of the used grinding blocks according to local legislation.

Fit each new grinding block squarely into the grinding plate location corner at the outer flat face of the grinding disc. Secure with a new wooden wedge, between the block and the inner face of the grinding block, knock the wedge into position using a suitable drift.

Note: Do not use a mix of old and new grinding blocks, this will cause rapid wear of the new blocks and could cause the machine to become uncontrollable, unstable and dangerous in use.

## Brush Seal Replacement

The machine is fitted with a flexible brush seal which will need replacement from time to time to maintain the efficiency of the dust control system. Follow the first five steps from the above procedure for changing discs. Drill out rivets and to remove the brush simply grasp one end and pull, the brush will come off the guard. To fit the new brush, align one end of the brush with the end of the guard and use a suitable drift to knock the brush onto the metal guard, working along until it is securely fitted



**IMPORTANT! ALWAYS ENSURE THE DUST GUARD IS RE-FITTED AND CORRECTLY LOCATED BEFORE OPERATION**

## CHECKING CHART

Based on normal & safe operating procedures and hours

		Before Operation	After Operation	Monthly	Every 3 Months	Every Year	If Damaged/Worn
Complete Machine	Check	X					
	Clean		X				
Pulleys & Belt	Check (Damage & Tension)	X	X				
	Tension			X			
	Replace					X	X
Vacuum Ports & Accesories	Check	X					
	Clean		X				
	Replace					X	X
Dust Seals	Check	X					
	Clean		X				
	Replace				X		X
Grinding Tools & Accesories	Check	X					
	Clean		X				
	Replace						X
Bearings & Seals	Check	X	X				
	Replace					X	X
Spring Loaded Stand	Check	X					
	Lubricate			X			
	Replace						X
Honda Engine	Check Fuel Level	X					
	Check Oil Level	X					
	Operational Check (No Load)	X					
	Review Manufacturer's Manual			X			
Electrical Motors	Visual Inspection	X					
	Clean Air Passages		X				
	Operational Check (No Load)	X		X			

# TRANSPORT

Use only suitable means of transport and lifting gear of sufficient capacity when loading or transporting the machine. Appoint an experienced instructor for the lifting operation. Always observe the instructions given in the operating manual when lifting the machine.

Use only suitable transport vehicles with sufficient load capacity. Secure the load carefully. Use suitable fastening points for securing. Before loading the machine or parts of it, secure the machine against inadvertent movement. Attach a suitable warning sign. Even in case of a minor change of location, the machine engine must be stopped.

Before using the machine again, make sure that such protection material or devices are properly removed. Parts which had to be removed for transportation of the machine must be refitted and secured carefully before the machine is used again. Before setting the machine in motion always check that all accessories are safely stowed.

The recommissioning procedure must be strictly in accordance with the operating instruction. Observe the instructions given in the operating instruction when reassembling and operating the machine.

---

# EXPORT CHECKING

Remove the transport packaging and dispose of it in an environmentally responsible way, recycle where possible. Check the machine for completeness and any visual signs of damage incurred during transit. Report any issues immediately to your supervisor, who should inform Trelawny straight away. Secure the machine against accidental start-up and rolling away.

The machine is supplied without engine oil & fuel. See our terms and conditions of sale on our website for more information.

## TROUBLESHOOTING

Troubleshooting	Cause	Action
<b>Engine stops suddenly or does not run correctly</b>	No fuel in the fuel tank.	Refuel fuel tank. (see safety section)
	Spark plug faulty.	Replace spark plug.
	Fuel blockage.	Check fuel line and strainer.
	Air filter partially blocked.	Replace air cleaner element.
	Low oil level. (Engine cut off switch is fitted)	Rectify leaks and replenish oil.
<b>Motor stops suddenly or does not run correctly</b>	Loose wiring, incorrect voltage or blown fuse	Check connections and power supply or replace fuse.
<b>Engine/motor runs but the grinding heads do not move.</b>	Drive belts slack or failed.	Replace belt or adjust tension
	Centrifugal clutch faulty on engine versions.	Replace clutch assembly
	No grinding tools fitted.	Check grinding discs for any damage, replace if necessary. Fit new grinding tools
<b>Grinder is slow or erratic</b>	Loose or a failed drive belts.	Adjust drive belt, or replace.
	Surface too rough.	Use Trelawny TFP200/260 Surface Planer to produce a flatter surface or to remove bulk of material prior to grinding. Change grinding tools to a coarser grade.
<b>Engine will not start</b>	No fuel in the fuel tank	Refuel fuel tank, see safety precautions.
	Low oil level	Rectify oil leaks and replenish oil.
	Water in fuel	Drain fuel tank, float chamber, and refuel
	Incorrect fuel in tank, i.e. diesel in petrol tank	Clean out fuel tank, all fuel lines and carburettor float chamber. Refuel with correct fuel.
	Spark plug faulty	Replace spark plug.
<b>Motor will not start</b>	Power supply is not switched on, blown fuse, voltage incorrect, loose wiring, or faulty motor.	Confirm that the power supply is switched on. Rectify loose wiring, replace blown fuse or replace motor.
Use above information in conjunction with the Honda Operation and Maintenance Manual.		
If problem has not been cured by any of the above actions, contact your local Trelawny SPT dealership for assistance.		

All rights reserved. Any unauthorised use or copying of the contents or part thereof is prohibited.  
This applies to trademarks, model denominations, part numbers and drawings.  
Use only genuine Trelawny spares. E & O E

**The use of non-Trelawny spare parts invalidates the warranty.**

# EXPLODED DIAGRAM

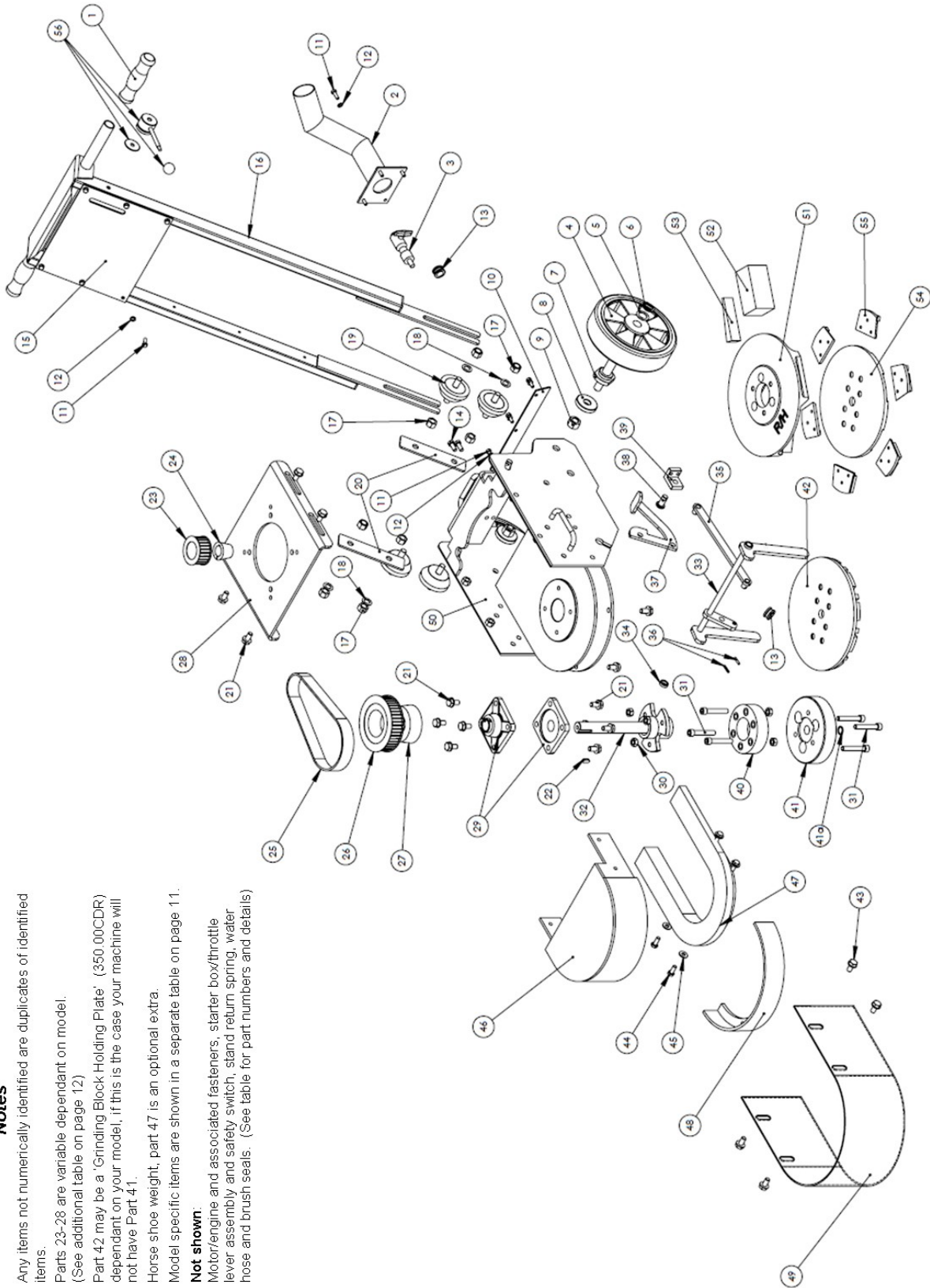

## Notes

- Any items not numerically identified are duplicates of identified items.
- Parts 23-28 are variable dependant on model. (See additional table on page 12).
- Part 42 may be a 'Grinding Block Holding Plate' (350.000CDR) dependant on your model, if this is the case your machine will not have Part 41.
- Horse shoe weight, part 47 is an optional extra.
- Model specific items are shown in a separate table on page 11.
- **Not shown:** Motor/engine and associated fasteners, starter box/throttle lever assembly and safety switch, stand return spring, water hose and brush seals. (See table for part numbers and details)

## PARTS LIST

Item NO.	PART NO.	DESCRIPTION	Item NO.	PART NO.	DESCRIPTION
1	822.2000	Rubber grip (x2)	44	831.0820	M8 x 20 hex bolt
2	345.9220	Vacuum takeoff tube	45	811.1008	M8 shake proof washer
3	828.0138/ 826.0138/ 819.0385	3/8" ball valve/bulkhead connector/hose tail	46	345.9223	Belt guard
4	350.9121	Wheel (x2)	47	345.2012	Weight
5	812.1001	20mm plain washer (x2)	48	345.2011	Removable section
6	814.1020	External circlip (x2)	49	345.9221	Dust skirt
7	345.9241	Stub axle (x2)	50	345.2010	Chassis
8	812.1016	M16 washer (x2)	54	350.5660	6 Segment Quick Fit Plate
9	824.1600	M16 Nyloc nut (x2)	55	See Page 17	Quick Fit Plate Tooling
10	345.9222	Rear dust skirt	56	350.9180, 350.9186	Throttle lever (petrol only)
11	831.0620	M6 x 20 hex bolt			
12	811.1006	M6 shake proof washer	Items not shown on exploded view		
13	843.0808	Water hose grommet		See page 17	Motor/engine
14	831.0820/ 811.1008	M8 x 20 hex bolt / M8 shake proof washer		345.9560A	230v Motor extension
15	N/A	See Item 16		350.9175	Throttle cable (petrol only)
16	992.0013	Handle Assembly (Including Starter Box Mounting Plate)		719.3000	Water hose (request 0.4M)
17	834.0500	1/2" UNF nyloc nut (x8)		345.9800	Deadman's switch box (No lever)
18	812.0500	1/2" plain washer (x4)		731.3154	Front brush seal
19	830.2000	Rubber mount 1/2" UNF		731.3155	Rear brush seal
20	345.9231	Handle clamping plate		713.5060	Stand return spring
21	831.1030/ 811.1010	M10 x 30 hex bolt M10 shake proof washer (x12)		350.9141	M12 x 25 c/sunk socket screw x4
22	350.9150	Drive key 8 x 7 x 25		345.9150	Woodruff Key N1 Shaft
23	See page 13	Motor pulley			
24	See page 13	Taper lock bush (motor)			
25	See page 13	Drive belt			
26	See page 13	Drive shaft pulley	Lafert Motor Components (see exploded view page 22)		
27	See page 13	Taper lock bush (drive shaft)	14	841.2650	Icar or Ducati start capacitor (Black)
28	345.9224 345.9225	Motor mounting plate for all other models Motor mounting plate for 345.2400D/QR, 345.2402D/QR, 345.2404D/QR and 345.2406D/QR	14	841.2660	Facon or Ducati run capacitor (White)
29	350.9116	25mm bearing assembly (x2)	5	841.2670 841.2672	SE01 Electronic starter switch SE02 Electronic starter switch
30	824.1000	M10 nyloc nut (x6)	24	841.2680	Fan
31	806.1060	M10x60 cap head bolt (x6)			
32	345.9235	Drive shaft	22	841.2690	Fan Cover 230v
33	345.9207A	Pedal operated stand assembly	22	841.2692	Fan Cover 110v & 400v
34	345.9208	Shaft bush (x2)	9/11	841.2694	Terminal box and lid
35	345.9204	Connecting rod	14	841.2650	Icar or Ducati start capacitor (Black)
36	813.0420	4mm roll pin	14	841.2660	Facon or Ducati run capacitor (White)
37	345.9201	Pedal	5	841.2670 841.2672	SE01 Electronic starter switch SE02 Electronic starter switch
38	345.9203	Pivot pin	24	841.2680	Fan
39	345.9202	Pedal bracket	22	841.2690	Fan Cover 230v
40	350.9146	Rubber coupling	22	841.2692	Fan Cover 110v & 400v
41	350.9143A	Diamond plate adapter	9/11	841.2694	Terminal box and lid
41a	809.3005	O-ring			
42	350.5620B	20 Segment diamond disc			
43	857.1020	Wing Knob M10 x 20			

# PARTS LIST MODEL SPECIFIC

Model variant by part number	Motor/engine/starter N4 shaft prior to 2014	Motor bolts	Motor nuts	Motor washers
345.2400D/345.2400QR	350.9500 Honda N4 Shaft	806.5610 (x2)	824.0800 (x2)	811.1008 (x4)
	345.9500 N1 Shaft			
345.2402D/345.2402QR	345.9550 Motor	831.1240 (x4)	824.1200 (x4)	812.0712 (x8)
	861.2002 Control System			
345.2404D/345.2404QR	345.9560 Motor	831.1040 (x4)	824.1000 (x4)	811.0710 (x8)
	861.2004 Control System			
345.2406D/345.2406QR	350.9575 Motor	831.1240 (x4)	824.1200 (x4)	812.0712 (x8)
	861.2007 Control System			
345.2342QR	875.1034 Motor	875.1095 (x4)	N/A	320.9236
	861.2010 Control System			

Model Variant

D = Diamond Disc

QR = Quick Release Segment Disc

## Drive components by model

Taper lock bushes include new grub screws (Not illustrated) for fitting. Also supplied with data sheet with torque setting and method.

The TCG250 is available in a range of configurations. The appropriate drive components for each variant are listed in the table below.

Note:

Honda N1 type shaft has a s v-belt pulley arrangement and is not a taper lock pulley, this item has to be purchased as an assembly.

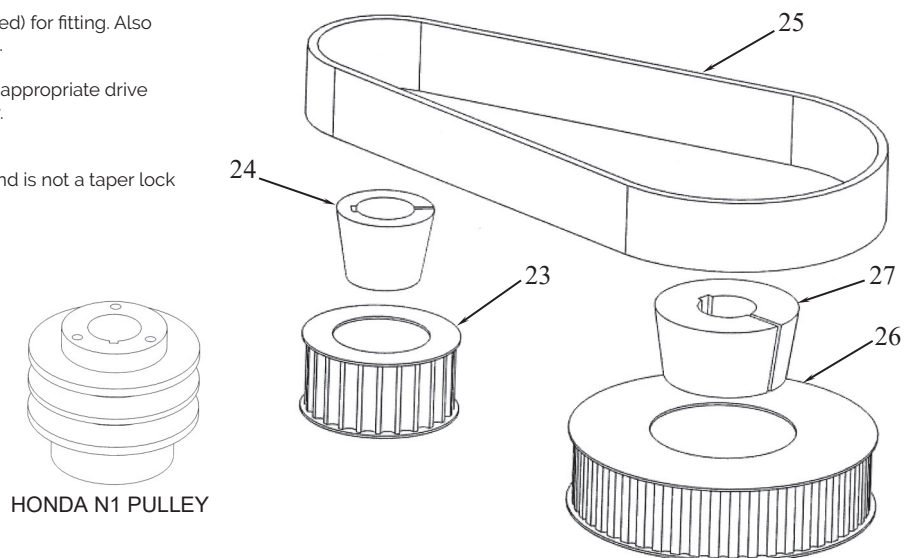

MODEL VARIANT BY PART NUMBER	(23) PULLEY (MOTOR)	(24) TAPER LOCK BUSH (MOTOR)	(25) BELT	(26) PULLEY (DRIVESHAFT)	(27) TAPER LOCK BUSH (DRIVESHAFT)
345.2400D/QR	345.9130 Honda N4 345.9126A Honda N1	345.9129A N4 See (23) N1	345.9136 Honda N4 345.9126V Honda N1	345.9134 Honda N4 345.9126D Honda N1	345.9126M Honda
345.2402D/QR	345.9130	345.9129B	345.9135	345.9123	345.9125
345.2404D/QR	345.9130	345.9127A	345.9135	345.9124	345.9124A
345.2406D/QR	345.9143	345.9142	345.9138	345.9132	345.9126M
345.2342QR	350.9124	992.1033	992.1031 (x2)	345.9126D	345.9126M

110v control system	part no: 861.2005
230v control system	part no: 861.2007
400v control system	part no: 861.2009
Button assy	Part no: 861.2018
110v 60Hz US Control System	Part no: 861.2010

These are not user-serviceable parts. In the event of failure, new assemblies will be need to be obtained from Trelawny.

# MEDIA TYPES - METAL BOND TOOLS

IMAGE	PART NO.	DESCRIPTION
	365.5495L	PCD Removal Diamond Anti-clockwise For removal of coatings, adhesives & toppings
	365.5495R	PCD Removal Diamond Clockwise For removal of coatings, adhesives & toppings
	365.5500	16 Grit Single (Quick Release) Soft Bond For very course grinding and thin coating removal
	365.5500/2	16 Grit Double (Quick Release) Soft Bond For very course grinding and thin coating removal
	365.5501	30 Grit Single (Quick Release) Soft Bond For Hard Concrete
	365.5502	30 Grit Single (Quick Release) Medium Bond For Medium Hardness concrete
	365.5503	30 Grit Single (Quick Release) Hard Bond For Soft Concrete or for very rough concrete
	365.5501/2	30 Grit Double (Quick Release) Soft Bond For Hard Concrete
	365.5502/2	30 Grit Double (Quick Release) Medium Bond For Medium Hardness concrete
	365.5503/2	30 Grit Double (Quick Release) Hard Bond For Soft Concrete or for very rough concrete
	365.5504/2	70 Grit Double (Quick Release) Medium Bond For Light Grinding and Scratch Removal
	365.5506/2	120 Grit Double (Quick Release) Medium Bond For Light Grinding and Scratch Removal
	350.5610RA 350.5616RA 350.5620RA	10 Segment Soft Bond Grinding Disc 16 Segment Soft Bond Grinding Disc 20 Segment Soft Bond Grinding Disc
	350.5610B 350.5616B 350.5620B	10 Segment Medium Bond Grinding Disc 16 Segment Medium Bond Grinding Disc 20 Segment Medium Bond Grinding Disc
	350.5610R 350.5616R 350.5620R	10 Segment Hard Bond Grinding Disc 16 Segment Hard Bond Grinding Disc 20 Segment Hard Bond Grinding Disc

### Guidance Notes

1. Only use tools with equal levels of wear. Mixing new and old tools will cause floor damage and or rapid wear on the new tools.
2. If the result of the grinding causes uneven floor wear or rapid tool wear check the bond/grit of the tool v's target floor surface.
3. Keep the machine moving at all times during operation for the best results.

# MEDIA TYPES - RESIN BOND TOOLS

IMAGE	PART NO.	DESCRIPTION
	365.5605	50 Grit Hybrid
	365.5610	100 Grit Hybrid
	365.5620	200 Grit Hybrid
	365.5602A	200 Grit Resin Bond
	365.5604A	400 Grit Resin Bond
	365.5608A	800 Grit Resin Bond
	365.5618A	1500 Grit Resin Bond
	365.5635A	3000 Grit Resin Bond
	350.5666	Polishing Adapter Plate Used to attach the "Polishing Tools" to the quick release plate

# LAFERT ELECTRIC MOTOR EXPLODED VIEW

## 110v & 230v Motors

Only the most commonly used motor components are carried in stock at Trelawny SPT Ltd.

These items are listed under the Lafert Motor heading in the parts list on the previous page.

**Note:**

Endsheild Drive End Flange not shown in item 3.

Items 27,28,29 & 30 are not used on the Grinder.

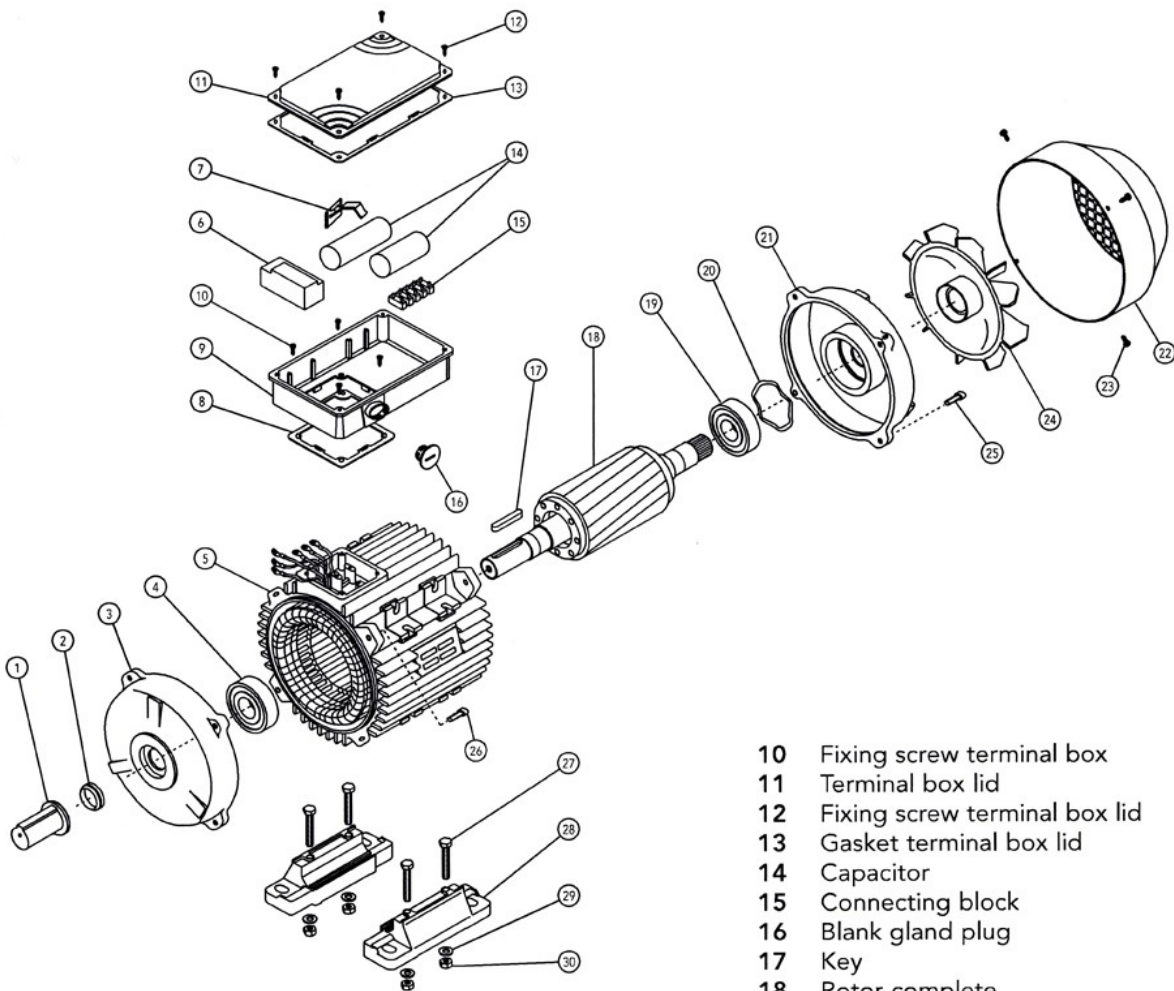

**PART DESCRIPTION**

- |   |                         |    |                                     |
|---|-------------------------|----|-------------------------------------|
| 1 | Shaft protection        | 10 | Fixing screw terminal box           |
| 2 | Dust seal drive end     | 11 | Terminal box lid                    |
| 3 | Endsheild drive end     | 12 | Fixing screw terminal box lid       |
| 4 | Bearing drive end       | 13 | Gasket terminal box lid             |
| 5 | Stator frame            | 14 | Capacitor                           |
| 6 | Starter                 | 15 | Connecting block                    |
| 7 | Fixing device capacitor | 16 | Blank gland plug                    |
| 8 | Gasket terminal box     | 17 | Key                                 |
| 9 | Terminal box            | 18 | Rotor complete                      |
|   |                         | 19 | Bearing non-drive end               |
|   |                         | 20 | Pre-load washer                     |
|   |                         | 21 | Endsheild non-drive end             |
|   |                         | 22 | Fan cover                           |
|   |                         | 23 | Fixing screw fan cover              |
|   |                         | 24 | Fan                                 |
|   |                         | 25 | Fixing bolt endsheild non-drive end |
|   |                         | 26 | Fixing bolt endsheild drive end     |
|   |                         | 27 | Fixing bolt motor feet              |
|   |                         | 28 | Motor feet                          |
|   |                         | 29 | Fixing washer motor feet            |
|   |                         | 30 | Fixing nut motor feet               |

# WIRING DIAGRAMS

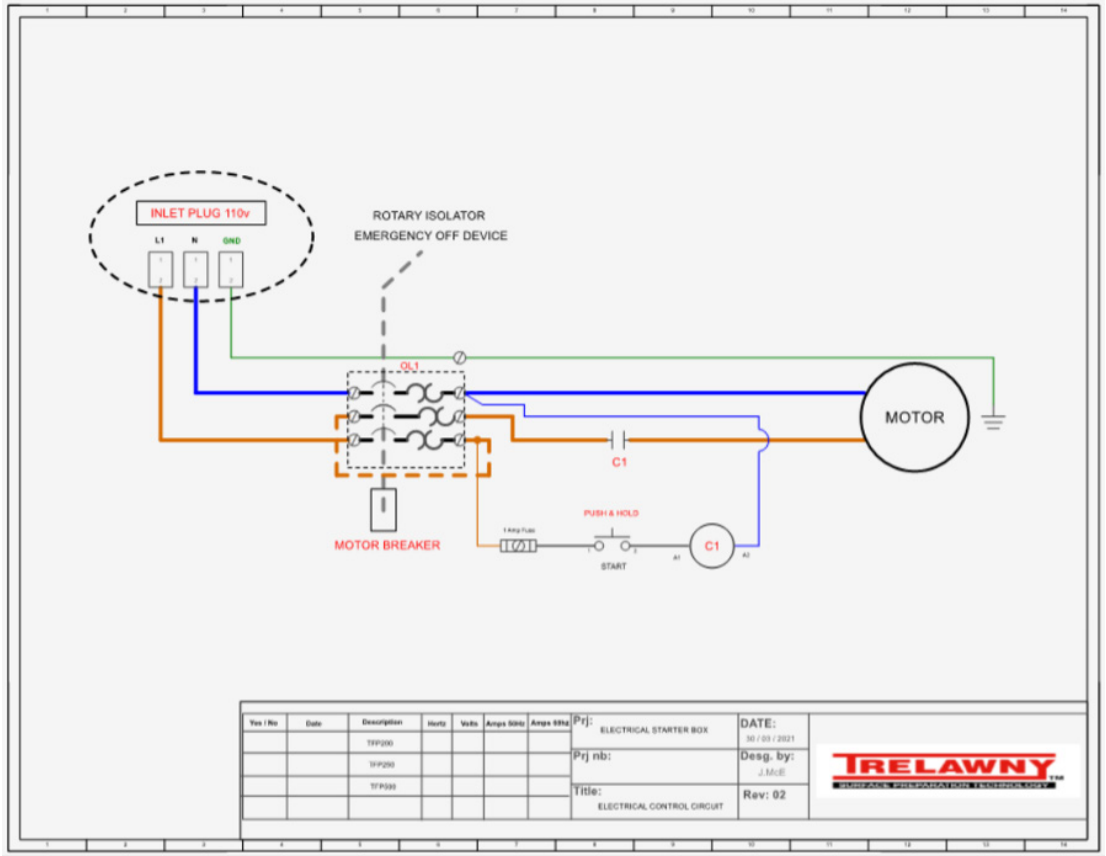
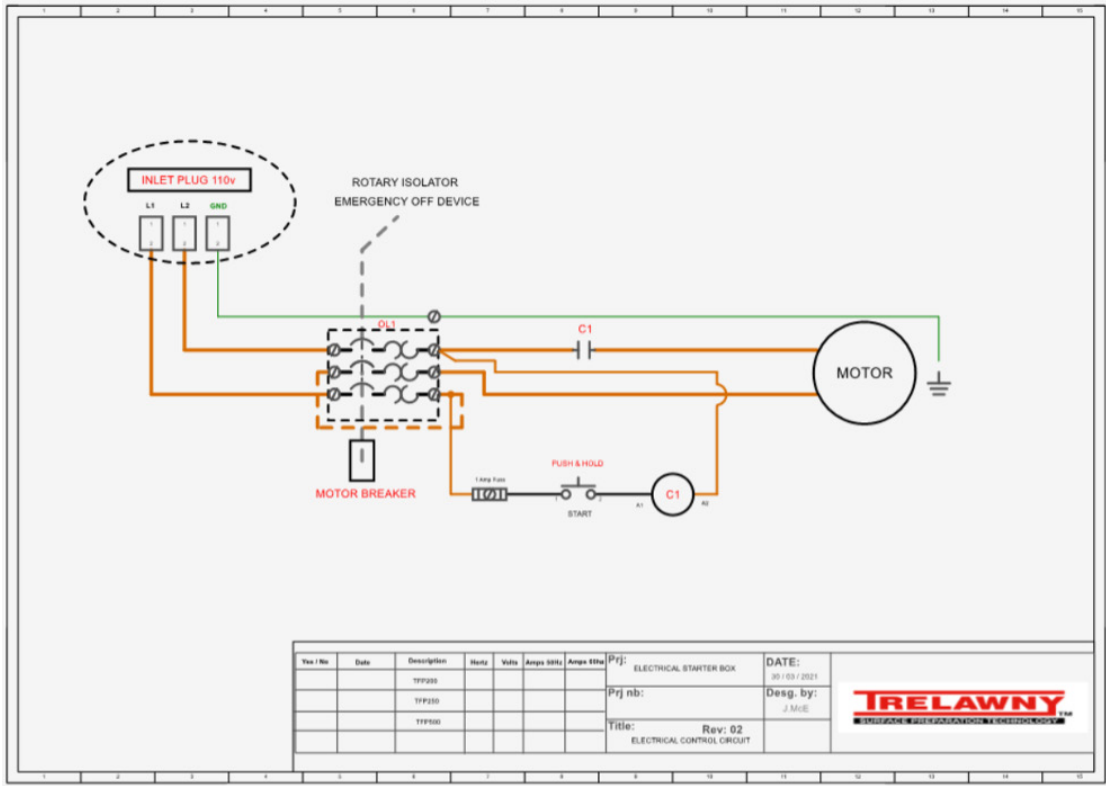

# WIRING DIAGRAMS

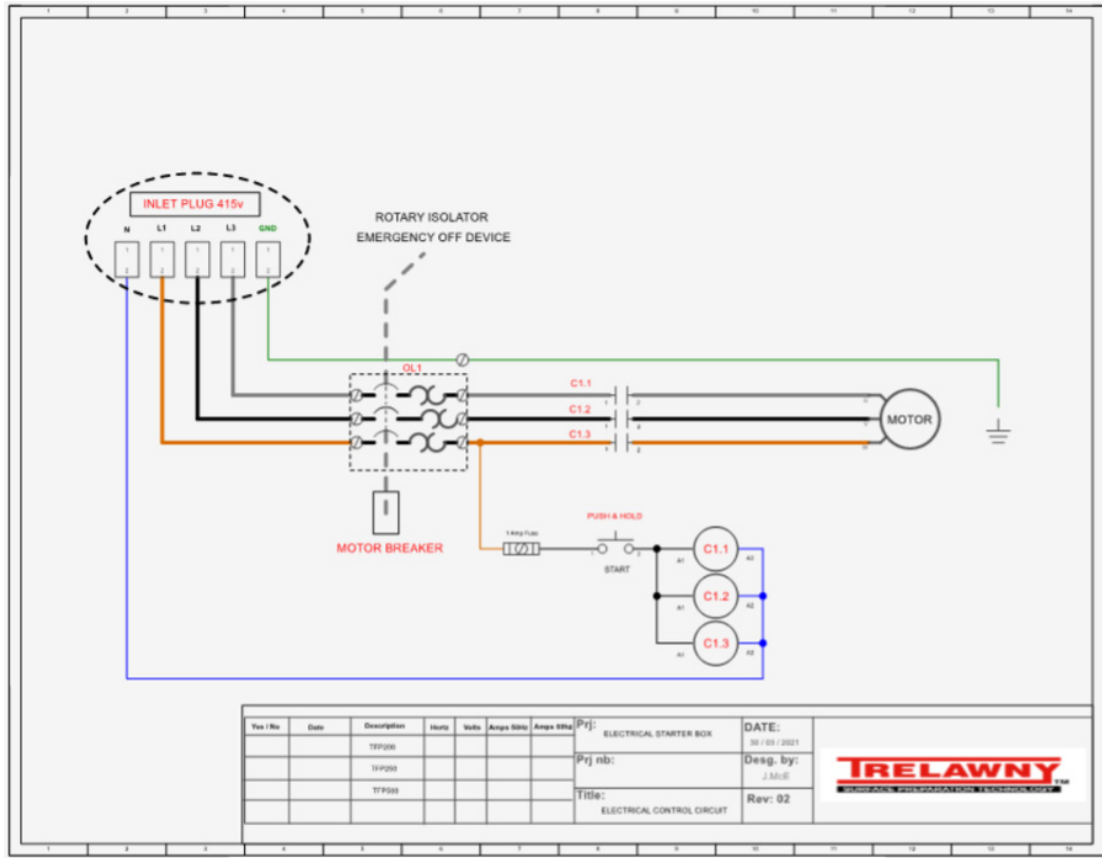

All rights reserved. Any unauthorised use or copying of the contents or part thereof is prohibited.  
 This applies to trademarks, model denominations, part numbers and drawings.  
 Use only genuine Trelawny spares.

**The use of non-Trelawny spare parts invalidates the warranty.**







## DEALER STAMP:



## NEED TO CONTACT US?

**Trelawny SPT Limited**

Trelawny House, 13 Highdown Road, Sydenham Industrial Estate,  
Leamington Spa, Warwickshire, CV31 1XT, United Kingdom

**Telephone:** +44 (0)1926 883781 Fax: +44 (0)1926 450352

**Email:** sales@trelawny.co.uk

**Website:** www.trelawny.co.uk

**Manual Part Number:**  
**735.3602**

