

4" ANGLE GRINDERS

OPERATION & MAINTENANCE MANUAL



CONTENTS

INTRODUCTION	3
GENERAL INFORMATION	3
EU DECLARATION OF CONFORMITY	4
UKCA DECLARATION OF CONFORMITY	5
DECLARATION OF CONFORMITY	6
SAFETY	7
HAND ARM VIBRATION	7
WARRANTY	7
ANGLE GRINDER SAFETY	8
PRE START CHECKS (DAILY)	8
AIR COMPRESSOR REQUIREMENTS	9
ASSEMBLY	9
OPERATION	9
GRINDING DISCS	10
DISC REPLACEMENT	10
SUGGESTED LUBRICANTS	10
SERVICING & MAINTENANCE	10
MACHINE STORAGE	10
TROUBLE SHOOTING	11
EXPLODED VIEW - 4" ANGLE GRINDER	12
PARTS LIST - 4" ANGLE GRINDER	13
TECHNICAL SPECIFICATIONS	14
NOTES	15
CONTACT US	16

INTRODUCTION

Thank you for choosing a product by Trelawny SPT Ltd, an innovative leading brand in the Surface Preparation sector.

This product has been manufactured under stringent quality standards to meet superior performance criteria. This manual contains the necessary maintenance information for you to ensure proper operation and care for this equipment.

In the unlikely event that you experience a problem please do not hesitate to contact your local Trelawny dealer or agent. We always welcome feedback and comments from our valued customers.



WARNING:

Carefully read through these original instructions before using your new TRELAWNY Equipment. Take special care to read warnings. TRELAWNY products have many features that will make your job faster and easier. Safety, performance, and dependability have been given top priority in the development of this product, making it easy to operate and maintain.



ENVIRONMENTAL PROTECTION:

The equipment, accessories and packaging should be sorted for environmentally friendly recycling. The plastic components are labelled for categorised recycling.

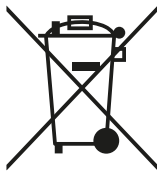

DISPOSAL:

Waste products should not be disposed of with household waste. Please recycle where facilities exist. Check with your local authority or retailer for recycling advice.

GENERAL INFORMATION

Before operating any TRELAWNY equipment, this manual must be read and understood by the operator, if in any doubt ask your supervisor before using this equipment. Failure to follow these instructions could result in damage to the equipment and/or personal injury.

Trelawny SPT Ltd disclaims all responsibility for damage to persons or objects arising as a consequence of incorrect handling of the equipment, failure to inspect the equipment

prior to starting work for damage or other faults that may influence the operation of safe working of the equipment, or failure to follow the safety regulations listed or applicable to the job site.

Operators should be familiar with the data given in the specification section. Please keep these instructions in a safe and accessible place.

EU DECLARATION OF CONFORMITY



EU Declaration of Conformity

We, **Trelawny SPT Ltd of 13 Highdown Road, Sydenham Industrial Estate, Leamington Spa, Warwickshire, CV31 1XT, GB** declare that the DoC is issued under our sole responsibility and belongs to the following product:

PART NUMBER

DESCRIPTION

SERIAL NUMBER

YEAR OF CONSTRUCTION



The object of the declaration described above is in conformity with the relevant **Union Harmonisation Legislation:**

- **2006/42/EC** Machinery Directive

The following harmonised standards and technical specifications have been applied:

- **EN ISO 11148-4:2012** Hand-held non-electric power tools — Safety requirements
Part 4: Non-rotary percussive power tools

Technical files are held by Indutrade Benelux BV, Anton Philipsweg 1, 1422 AL Uithoorn, Netherlands

Notified Body:
Not Applicable. Machinery is not listed under ANNEX IV of the Machinery Directive.

Place of Declaration:
Trelawny SPT Ltd, 13 Highdown Road, Sydenham Industrial Estate, Leamington Spa, Warwickshire, CV31 1XT, GB

Date of Declaration:
December 2024

Signed by:

Daniel Rowledge
Managing Director

UKCA DECLARATION OF CONFORMITY



UKCA Declaration of Conformity

We, **Trelawny SPT Ltd of 13 Highdown Road, Sydenham Industrial Estate, Leamington Spa, Warwickshire, CV31 1XT, GB** declare that the DoC is issued under our sole responsibility and belongs to the following product:

PART NUMBER.....

DESCRIPTION

SERIAL NUMBER

YEAR OF CONSTRUCTION

The object of the declaration described above is in conformity with the relevant **Statutory Requirements:**

- **2008 No. 1597** Supply of Machinery (Safety) Regulations 2008

The following designated standards and technical specifications have been applied:

- **BS EN ISO 11148-4:2012** Hand-held non-electric power tools — Safety requirements
Part 4: Non-rotary percussive power tools

Technical files are held by **Daniel Rowledge** at the Trelawny address stated above.

Approved Body:

Not Applicable. Machinery is not listed under ANNEX IV of the Machinery Directive.

Place of Declaration:

Trelawny SPT Ltd, 13 Highdown Road, Sydenham Industrial Estate, Leamington Spa, Warwickshire, CV31 1XT, GB

Date of Declaration:

December 2024

Signed by:

Daniel Rowledge
Managing Director

DECLARATION OF CONFORMITY

<p>CZ Prohlášení o přizpůsobení My, společnost Trelawny SPT Limited podávamej daňové příznání, že výrobek a dodávka výrobku název výrobku Model, výrobní číslo Rok výroby Pro které se průkaz týkající, je přizpůsobení s zásobou od následující příkazov a jejich pohotovostní: 2006/42/EC Příkaz soustrojí 2014/35/EC Příkaz nízkého napětí (upotřebitelné jedině do výrobku použité elektrické energie)</p>	<p>LT ATITIKTIES DEKLARACIJA Mes, Trelawny SPT Limited Prisiidami visą atsakomybę deklaruojame, kad tiekiamas / gaminamas produktas Produkto pavadinimas Modelis, serijos numeris Pagaminimo Kuriam laikoma ši deklaracija, atitinka šių direktyvų, norminių aktų ir su jais susijusių, standartų reikalavimus: 2006/42/EC Įtango direktyva 2014/35/EC Žemos įtampos direktyva (laikoma tik elektriniams įrengimams)</p>
<p>DE Übereinstimmungserklärung Wir, Trelawny SPT Limited erklären, dass unter unserer alleinigen Verantwortung für die Lieferung und Herstellung des Produktes Name des Produktes Model, Seriennummer Jahr der Herstellung auf welches sich dieses Dokument bezieht, stimmt mit den Vorgaben der folgenden Direktive, normativen Dokumente und deren jeweiligen Masstabe ein: 2006/42/EC Maschinieriedirektive 2014/35/EC Niederspannungsdirektive (nur zutreffend auf Produkte, die Strom benutzen)</p>	<p>MT DIKJARAZZJONI TA KONFORMITA Ahna, Trelawny SPT Limited Niddikjaraw li ahna responsabbli kompletament għal provista / maniffattura tal-prodott hawn 1msemmi: Isem Il-Prodott Mudell, Serial number Sena la 'produzzjoni Dan id-dokument magħmul għal prodott imsemmi hawn fuq, li huwa skond il-provizjonijiet imsemmija fid-dokumenti tal-klassi tax-xogħol: 2006/42/EC Machinery Directive 2014/35/EC Low Voltage Directive (tapplika biss għal prodotti li jahdmu bi-elekttriku)</p>
<p>DK Erklæring om overensstemmelse Vi, Trelawny SPT Limited Erklærer hermed at under vores ene forhandling ansvar for vores forhandling/produktion af produktet Produkt navn Model, serie nummer Produktionsår For hvilket dette dokument referer, at deler i overensstemmelse med bestemmelser af følgende direktiver, normative dokumenter og deres relevante standard: 2006/42/EC Machinery directive 2014/35/EC Low voltage directive</p>	<p>NL EENVORMIGHEIDSVERKLARING Wij, Trelawny SPT Limited Verklaaren dat wij de volledige verantwoordelijkheid dragen voor het leveren/fabriceren van het volgende product: Naam van het product Type, Serienummer Productiejaar En verklaaren dat het product waarnaar dit document verwijst eenvoudig is met de voorzieningen van de volgende Richtlijn(en). Normatieve Documenten en hun relevante Standaarden: 2006/42/EC MACHINERIECHTLIJN 2014/35/EC LAAGSPANNINGSRICHTLIJN (uitsluitend van toepassing bij producten die elektrische stroom gebruiken)</p>
<p>EE TOOTE VASTAVUSE DEKLARATSIOON Meie, Trelawny SPT Limited Deklareerime, et vastutame järgmise varustuse/toote müügi eest Toote nimetus Mudel, Seeria number Aegseda tootmisajaku Arvutud dokument käsitleb toote vastavust järgmistele direktiividele, normatiividele ja nendega samaväärsetele standardidele: 2006/42/EC MASINIA DIREKTIIVID 2014/35/EC MADALPINGE DIREKTIIVID (Kohandatakse vaid tootele, mis kasutavad elektrivoolu)</p>	<p>PL Deklaracja Zgodności My, Firma Trelawny SPT Limited. oświadczamy w naszej odpowiedzialności, że produkcja i dostawa urzadzzenia Nazwa produktu Model, numer seryjny Rok produkcji do którego ten dokument należy, jest zgodne z klauzulami następujących zarządzeń i ich istotnych standardów: 2006/42/EC Zarządzenie mechaniczne 2014/35/EC Zarządzenie niskiego napięcia elektrycznego (Zastosowanie tylko przy urządzeniach elektrycznych)</p>
<p>ES Declaración de Conformidad Nosotros, Trelawny SPT Limited Declaramos que bajo nuestra completa responsabilidad de la fabricación/suministro del producto Nombre del Producto Modelo, No de Serie Año de producción A quien este documento se refiere, está de acuerdo con lo relacionado en la Directriz, Normativa Documentada y sus relevantes standards: 2006/42/EC Directorio de Maquinaria 2014/35/EC Directorio de Bajo Voltaje (Aplicable solamente a productos que funcionen con electricidad)</p>	<p>PT DECLARAÇÃO DE CONFORMIDADE CE A empresa TRELAWNY SPT LIMITED Declara, sob sua inteira responsabilidade, que o fornecimento/fabrico do seguinte produto: Designação do produto Modelo, Número de Série Ano de produção a que esta declaração se refere, está em conformidade com o preceituado nas Directivas e Normas Comunitárias abaixo indicadas: 2006/42/EC DIRECTIVA DE MÁQUINAS 2014/35/EC DIRECTIVA DE BAIXA VOLTAGEM (Aplicável apenas a produtos que utilizam energia eléctrica)</p>
<p>FI ILMOITUSVAHVISTUS Me, Trelawny SPT Limited Valmistamme tuotteen toimittamisesta/valmistamisesta Tuotteen nimi Malli, sarjanumero Valmistusvuosi Täällä todistuksella vahvistamme säädökset seuravien ohje/ohjesien, Yleisin papereihin ja niihin liittyvät vaatimukset: 2006/42/EC KONEISTON OHJEET 2014/35/EC PIENJÄNNITTE OHJEET (tarvitaan ainoastaan tuotteille jotka käyttävät sähkövoimaa)</p>	<p>RU СВИДЕТЕЛЬСТВО О СООТВЕТСТВИИ Мы, Trelawny SPT Limited Заявляем, что несем полную ответственность за поставку/производство нижеуказанной продукцией наименование изделия Модель, серийный номер Год выпуска на которую выдано настоящее Свидетельство, и которая соответствует положениям следующей(их) директиве(ы), нормативным документам и относящимся к ним стандартам: 2006/42/EC ДИРЕКТИВА ПО МЕХАНИЗМАМ 2014/35/EC ДИРЕКТИВА ПО НИЗКОВОЛЬТНОМУ ОБОРУДОВАНИЮ (распространяется только на изделия с электропитанием)</p>
<p>FR DÉCLARATION DE CONFORMITÉ Nous, soussignés Trelawny SPT Limited déclarons que le produit sous-nommé Nom du produit Modèle et Numéro de Série Année de production et pour lequel nous prenons entière responsabilité pour sa fourniture et manufacture, est conforme aux clauses des directives suivantes documents normatifs et normes qui s'y appliquent: 2006/42/EC DIRECTIVE POUR LA MACHINERIE 2014/35/EC DIRECTIVE POUR BAS VOLTAGE (n'est applicable qu'aux produits utilisant l'énergie électrique)</p>	<p>SE FÖRSÄKRAN OM ÖVERENSSTÄMMELSE VI, TRELAWNY SPT LIMITED FÖRKLARAR ATT VI MED ENSAMT ANSVAR ANSKAFFAT / TILLVERKAT PRODUKTEN PRODUKTNAMN MODELL och SERIE NUMMER Tillverkningsår TILL VILKEN DETTA DOKUMENT HÄNVISAR ÄR I ÖVERENSSTÄMMELSE MED FÖLJANDE DIREKTIV, NORMATIVA DOKUMENT OCH DERAS RELEVANTA STANDARDER 2006/42/EC MASKINDIREKTIV 2014/35/EC LÅGSTRÖMSDIREKTIV (TILLÄMPLIG PÅ ELEKTRISK DRIVNA PRODUKTER)</p>
<p>GR ΔΗΛΩΣΗ ΠΙΣΤΟΤΗΤΑΣ Η εταιρεία Trelawny Spt Limited Δηλώνει ότι έχει τη μοναδική ευθύνη ως κατασκευαστρια / προμηθευτρια του παρακάτω προϊόντος περιγραφη προϊόντος μοντέλο, αριθμός σειράς έτος παραγωγής και στο οποίο αναφέρεται αυτή η δήλωση, είναι συμβατό με τις προδιαγραφές που ορίζονται στις ακόλουθες Κοινοτικές Οδηγίες Ελεγκτικές Διατάξεις κι άλλες σχετικές προδιαγραφές 2006/42/EC ΟΔΗΓΙΑ ΠΕΡΙ ΜΗΧΑΝΗΜΑΤΩΝ 2014/35/EC ΟΔΗΓΙΑ ΠΕΡΙ ΧΑΜΗΛΗΣ ΤΑΣΗΣ (αφορά μόνον προϊόντα που λειτουργούν με ηλεκτρικό ρεύμα)</p>	<p>SI IZJAVA O SKLADNOSTI Trelawny SPT Limited pod polno odgovornostjo izjavljamo, da so spodaj navedeni proizvodi, ki jih dobavljamo/producirajamo: Ime proizvoda Model, serijska številka Leto proizvodnje na katere se ta dokument nanaša, proizvedeni v skladu z določili naslednjih direktiv, normativnih dokumentov in njihovih relevant- nih standardov: 2006/42/EC DIREKTIVA O STROJIH 2014/35/EC DIREKTIVA O STROJIH Z NIZKO VOLTAŽO (nanaša se samo na proizvode na električni pogon)</p>
<p>HU MEGFELELŐSÉGI NYILATKOZAT Mi, A "Trelawny SPT Limited" cég Felelősségünk tudatában kijelentjük, hogy mint a termék szállítója/gyártója Termék neve Típus, Sorozatszám Gyártási év amelyre jelen dokumentum vonatkozik, megfelel az alábbi Irányelv(ek), Irányadó Dokumentumok előírásainak, és az azokat meghatározó szabványoknak: 2006/42/EC GÉPÉSZETI IRÁNYELVEK 2014/35/EC KISFESZÜLTÉSŰ IRÁNYELVEK (Csak az elektromos meghajtású gépeknél)</p>	<p>TR UYGUNLUK BEYANI Trelawny SPT Limited Aşağıdaki, üretim ve tedarikinden tek başına sorumlu olduđu ürünün Ürün adı Model/Seri no Üretim yılı bu belgeğin ilgili olduđu apaşğıdaki yönetmeliklerin, norm belgelelerinin ve ilgili standartları'nın koşullarına uygun olduđunu beyan eder: 2006/42/EC MAKÝNALAR YÖNETMELÝĐÝ 2014/35/EC DÜĐUK GERÝLÝM YÖNETMELÝĐÝ (Yalnızca elektrikle çalıřan ürünlerde geçerlidir)</p>
<p>IT DICHIARAZIONE DI CONFORMITA La Societa' Trelawny SPT Limited Dichiaro, sotto la propria responsabilita', che la fornitura / produzione del prodotto Nome prodotto Modello, codice Anno di produzione a cui si riferisce tale documento e' conforme alle seguenti Direttive, ai documenti della Normativa ed ai relativi standard: 2006/42/EC DIRETTIVA SULLE APPARECCHIATURE 2014/35/EC DIRETTIVA SUL BASSO VOLTAGGIO (applicabile esclusivamente per i prodotti che utilizzano energia elettrica)</p>	

SAFETY

DO:

- Wear personal protective equipment including safety goggles, footwear, ear defenders and gloves. In some environments it will be necessary to wear facemasks or breathing apparatus.
- Be aware that this equipment can create dust and flying debris.
- Keep hands, feet and clothing away from moving parts.
- Follow the prestart checks detailed in this manual.
- Ensure that the workplace is well ventilated.
- Be aware of others working around you.
- Always follow safe-working practices.
- Inspect the equipment prior to using.
- Store this equipment in a secure and dry environment.

DO NOT:

- Modify this equipment in any way. This will invalidate the warranty and could lead to serious injury.
- Allow the equipment to run unattended.
- Use petrol (gasoline), thinners or any other high flash point solvent to clean the equipment.
- Disassemble or repair unless Trelawny trained.
- Permanently fix the operating lever or button in the on/run position.

HAND ARM VIBRATION

Trelawny Equipment may cause hand-arm Vibration Syndrome injury if their use is not adequately managed.

We advise you to carry out a risk assessment and to implement measures such as; limiting exposure time [i.e. actual trigger time, not total time at work], job rotation, ensuring the tools are used correctly, ensuring the tools are maintained according to our recommendations, and ensuring that the operators wear personal protective equipment (PPE) particularly gloves and clothing to keep them warm and dry.

Employers should consider setting up a programme of health surveillance to establish a benchmark for each operator and to detect early symptoms of vibration injury.

We are not aware of any PPE that provides protection against vibration injury by attenuating vibration emissions.

See 'Specifications' section for vibration emission data.

Further advice is available from our Technical Department.

We strongly advise you to visit the Health & Safety Executive website <http://www.hse.gov.uk/vibration> - this site provides excellent advice and information on HAV and currently, includes a Hand-Arm Vibration Exposure Calculator that is easy to use to work out the daily vibration exposure for each of your operators.

WARRANTY

When you choose TRELAWNY, you're investing in a product engineered for strength, durability, and unwavering reliability. Our equipment is built to endure the toughest challenges, showcasing nearly 80 years of craftsmanship in Surface Preparation Technology. We take pride in being the industry benchmark, offering not just a tool but a lasting companion for tough jobs, backed by a 12-month warranty for peace of mind.

Register your TRELAWNY product within 30 days of purchase by scanning the QR code to activate your warranty and enjoy the full support from our team.

PLEASE RETAIN YOUR PROOF OF PURCHASE, AS IT WILL BE REQUIRED TO PROCESS ANY WARRANTY CLAIMS.

The following are not covered under the Trelawny warranty:

- Damage caused by abuse, misuse, dropping or other similar damage caused by or as a result of failure to follow assembly, operation or user maintenance instructions.
- Alterations, additions or repairs carried out by persons other than Trelawny or their recognised agents.

- Transportation costs to and from Trelawny or their recognised agents, for repair or assessment against a warranty claim, on any equipment.
- Materials and/or labour costs to renew, repair or replace components due to fair wear and tear.

In no case whatsoever shall the Customer be entitled to claim damages, in particular but not be limited, loss of profit and other direct or indirect or consequential damage. This exclusion of liability, however, does not apply to unlawful intent or gross negligence on our part, but does apply to unlawful intent or gross negligence of persons employed or appointed by us to perform any of his obligations.



All warranty claims should firstly be directed to Trelawny SPT Ltd. Please provide, part number, serial number and proof of purchase, either by telephone or E-mail.

Tel: +44 (0)1926 883781

Email : warranty@trelawny.com

ANGLE GRINDER SAFETY

- Read the instructions before using. All operators must be fully trained in its use and be aware of these safety rules.
- Do not exceed the maximum working air pressure.
- Use personal protective safety equipment.
- If the tool appears to malfunction remove from use immediately and arrange for service and repair.
- If the tool is used with a balancer or other support device ensure that it is fixed securely.
- Always keep hands away from the working attachment fitted to the tool.
- The tool is not electrically insulated. Never use the tool if there is any chance of it coming into contact with a live electrical source.
- When using the tool adopt a firm footing and/or position and grip the tool firmly to be able to counteract any forces or reaction forces that may be generated whilst using the tool.
- Use only correct spare parts. Do not improvise or make temporary repairs.
- Do not lock, tape, wire, etc. the on/off valve in the run position. The trigger/lever etc. must always be free to return to the 'off' position when it is released.
- Always shut off the air supply to the tool, and depress the trigger/lever to release air from the feed hose before fitting, adjusting or removing the working attachment.
- Check hose and fittings regularly for wear, replace if necessary. Do not carry the tool by its hose and ensure the hand is remote from the on/off control when carrying the tool with the air supply connected.
- Take care against entanglement of moving parts of the tool with clothing, ties, hair, cleaning rags, etc. This will cause the body to be drawn towards the tool and can be very dangerous.
- Users will adopt safe working practices and observe all relevant legal requirements when installing, using or maintaining the tool.
- Do not install the tool unless an easily accessible and easily operable on/off valve is incorporated in the air supply.
- Take care that the tool exhaust air does not cause a problem or blows on another person.
- Never lay a tool down unless the working attachment has stopped moving.
- A grinding wheel should only be fitted by a competent person trained to do so. The wheel must be of the correct size and speed rating.
- Check the speed of the grinder at least once per week, if it is in regular use, with an accurate tachometer.
- The tool must only be used with the grinding wheels as set out in section "Use of the Tool" and shown on parts list. Carry out the instructions as set out in "Putting into Service".
- Many countries have local or national rules re the use and fitting of grinding wheels. Make sure such rules are observed.
- Use a barrier to prevent sparks causing a hazard to the operator, any other person or anything within the vicinity of the sparks.
- If a wheel guard becomes damaged or has withstood a wheel breakage, the guard must be changed.
- Do not use chipped or cracked grinding wheels.
- Always wear impact resistant eye protection.
- Use only the disc plates, Items (65) and (66) provided with the grinder for locating and clamping the wheel. Never use substitutes. Use the paper blotter fixed to the wheel as this ensures even tightness when the wheel is secured.
- Tighten the wheel plates sufficiently to prevent wheel spin off when the grinder is turned off. Do not tighten excessively as this may crack the wheel.
- The noise from the tool or the process noise of the grinding operation may be such that hearing protection should be worn.
- Avoid inhaling dust from the grinding process. Wearing of a breathing mask is recommended. Grinding certain materials may mean that special breathing precautions are necessary. Seek advice before using the tool.
- Always ensure that the work piece is firmly supported so that it cannot move during the grinding process.
- If the grinder is dropped do not use unless the wheel is first checked for damage by a competent person.
- When not in use the grinder should be stored in a safe place where it will not be damaged. If a tool has not been used for a period of time check the tool as for the first time of using.
- Be aware that if the grinding process causes high vibration, special precautions should be taken.
- The operator should be aware that the grinding wheel will continue to rotate after the power supply has been shut off. This could cause a hazard.
- Always store grinding wheels in accordance with the manufacturer's instructions.
- Check frequently that the spindle thread has not become damaged or worn.
- Always ensure that the grinding wheel has a higher permissible running speed to the speed of the grinder.

PRE START CHECKS (DAILY)

- The compressed air must be free from water and dirt. Always clear the air hose before connecting to the tool.
- Ensure that no moisture (condensation) is present in the air hose.
- Ensure a minimum of 10mm (3/8") bore air hose is used and all couplings are secure, leak free and in good condition.
- Limit the length of air hose to 30M. Where extra length is necessary, for each additional 15M of air hose used, the pressure drop is approximately 0.21bar (3psi).
- For safe and efficient operation, the correct operating pressure is 6.2bar (90 psi).
- Do not let the operating pressure fall below 5.5bar (80psi) or rise above 6.9bar (100 psi).
- In particularly cold weather it is recommended that a proprietary anti-freeze lubricating oil is used.

AIR COMPRESSOR REQUIREMENTS

- Use correct air hose size (refer to tool specifications). The hose should be just long enough to serve the working area. Excessive hose length will cause pressure drop.
- Make sure air compressor supplies clean, dry air at correct CFM for the tool.
- Set air pressure to 90 psi. Excess air pressure and or unclean air will shorten the tool's life and may create a hazardous situation.
- Drain water from air compressor tank daily, as well as any condensation from air lines. Water in the air line may enter the tool and cause damage.
- Change filters on the air system on a regular basis.
- Air-line pressure may be increased accordingly to compensate for extra-long air hoses (usually over 25 feet). Inside diameter of hose should be minimum 3/8-inch.
- Equip the air compressor intake with a replaceable air filter that can be easily cleaned.
- Use safety shut-off valves so air flow can be stopped quickly in case of a line break.
- When using multiple hoses, air hoses should be larger than leader hose. Join multiple hoses directly, rather than with quick connect fittings which may cause pressure drops and tool power reduction.
- Use anti-whip devices across hose couplings to prevent hose from whipping in the event of a hose failure or coupling disconnect.
- Always use moisture traps at the compressor for the main distribution line. Use moisture traps and in-line oilers on each downline that is to be used for air tools. Place oiler as close to air tool as possible for best lubrication.

ASSEMBLY

- Install handle into threaded hole on either left or right side of grinder.
- Press spindle lock while rotating outer flange, until you feel spindle lock engage. Continue pressing spindle lock.
- Place pin wrench into holes of outer flange. Rotate counter clockwise to loosen flange, and remove it.
- Install grinding wheel. Reinstall and tighten outer flange, using pin wrench (clockwise) and spindle lock.
- Remove protective cap from air inlet. If an in-line oiler is not being used, add 4 or 5 drops of air tool oil (not included) into the air inlet.
- Blow out air line to remove any dirt or moisture, then connect air supply hose to tool. Set air pressure to 90 psi.
- **IMPORTANT:** Connecting a quick-change coupling directly to the tool is not recommended, as vibration may cause the connection to fail. Instead, add a leader hose and install any quick-change couplings further down the line.

OPERATION

Prior to operating the tool check:

That all parts of the tool are fully screwed/fitted together and secure, if you are in any doubt ask your supervisor before using this equipment.

That the air pressure is correct for this tool 6.2 bar (90 p.s.i.).

That a liberal amount of lubricant has been put into the air inlet of the tool. (See suggested lubricants)

Safe use of this tool requires a solid stance and secure foothold, the tool may be used in other postures but care must be taken that the operator adopts a firm and stable position.

Maintain contact with the work surface with sufficient pressure only to keep the tool from bouncing.

Excessive operator pressure will not improve the tool efficiency but could cause premature tool failure and operator fatigue.

Hold grinder with a light but secure grip. Slide throttle lock out of the way while pressing throttle lever. Pressure against throttle lever determines speed of rotation.

Position grinding wheel against work piece with a steady pressure. Wheel rotation is clockwise when viewed from above the tool.

Release throttle lever to stop grinder.

To reposition disc guard, push tab toward housing, rotate guard to desired position, then release tab. Continue rotating guard until it "clicks" into position.

GRINDING DISCS

For use on steel only.

Flap Wheel

For the removal aggressive removal of paint and coatings and heavy rust from steel work, leaving a bright finish on steel work.

Wire Cup Brush

For the removal of light paint, other coatings and rust from steel work.

Use of tool

This angle grinder is designed for use with reinforced resin bonded depressed centre grinding wheels that have a permitted rotational speed in excess of the machines specifications.

The tool is designed for light grinding and dressing of welds, etc, but not for cutting off.

DISC REPLACEMENT

- Only personnel trained in the Abrasive Wheels Regulations 1970 standard for the correct fitting of grinding wheels must maintain this tool.
- PUWER 98, which covers the selection and use of work equipment in general, revoked the remaining provisions of the Abrasive Wheels Regulations 1970 (these dealt with the training, competence and appointment of people to mount abrasive wheels).
- See also ANSI B7.1 Safety code for the use, care and protection of abrasive wheels.
- Disconnect tool from air supply
- To dismantle, insert the peg spanner into disc nut (and with a spanner on the flats of gear shaft unscrew disc nut, take off disc and unscrew disc receiver.
- Check that it is screwed tightly to the shaft and locates the bore of the grinding wheel on the spigot of the disc receiver and screw on disc nut item using the spanners provided. It should be tight enough to prevent wheel spin off when the air supply is shut off.

SUGGESTED LUBRICANTS

Oil the tool daily before use. Put a few drops of one of the following zinc free air tool lubricants through the air inlet:

SHELL S22 or R10, CASTROL Hyspin ZZ32

It is recommended that an inline lubricator be installed in the air hose adjacent to the tool.

Cleaning

If operation becomes unproductive, dismantle and clean with a highly refined paraffin.

Immediately after cleaning, thoroughly oil the tool with one of the recommended lubricants.

SERVICING & MAINTENANCE

- The grinder should be lubricated daily (or before each use) with air tool oil through the air inlet. During continual operation, it should be re-oiled every 1 to 2 hours. This can be done with an in-line oiler, or manually. If done manually, proceed as follows:
 - Disconnect air hose from tool.
 - Place 4 or 5 drops of air tool oil into air inlet. NOTE: Air tool oil not provided.
 - Re-connect air. Run grinder at low throttle without load for a few seconds to distribute the oil throughout tool.
- When finished operating grinder, disconnect air hose. Wipe off housing with a dry cloth. Place 4 or 5 drops of air tool oil into air inlet; re-connect air and run tool for a few seconds to distribute the oil. Disconnect air.
- The angle grinder has been pre-greased from the manufacturer, and it is generally unnecessary to grease the tool during its normal life. However, should the tool require future servicing, a grease fitting is supplied atop the housing.

MACHINE STORAGE

Short period storage: up to 3 months

Clean outside of the equipment and inspect the consumable items for wear, replace any worn parts as required. Insert a liberal quantity of air tool through the air inlet and run briefly to ensure that the internal components are coated with oil. Cover and store the equipment in a dry location.

Long period storage: over 3 months

Follow instructions set out in 'short period storage'. Additionally lubricate any exposed moving parts with one of the suggested lubricants. Repeat this process every 3 months.

TROUBLE SHOOTING

FAULT	POSSIBLE CAUSE	ACTION
Tool will not start	Valve body closed or obstructed	Inspect and clear any obstructions
	Dirt or deposits on components	Flush tool with solvent. Check and clean compressor air filter. Clean external areas of the tool. If the problem persists, disassemble the tool, clean and lubricate internal parts.
	Rotor vanes are worn	Replace vanes (entire set)
	Throttle trigger malfunction	Ensure that the trigger has not been taped or wired in the open position. Do not use quick release couplings to switch tool off.
	Bearing(s) worn	Disassemble and inspect bearings. Grease or replace as needed.
Tool continues to run with trigger released	Throttle trigger malfunction	Ensure that the trigger has not been taped or wired in the open position. Do not use quick release couplings to switch tool off.
Poor performance or lack of power	Low air pressure.	Ensure that the air pressure is correct at 90psi, max 100psi.
	If tool has been left for some time without use, the oil may dry out slightly, causing a sticky residue.	Strip tool down, clean and re-oil.
	Moisture or obstruction in air hose	Air supply must be clean and dry. Clean out air hose and remove any kinks or bends.
	Incorrect size of air line, hoses, fittings or couplings.	Use appropriate sized air lines/hoses. Verify correct fittings and couplings
	Rotor vanes are worn	Replace vanes (entire set)
	Dirt or deposits on components	Flush tool with solvent. Check and clean compressor air filter. Clean external areas of the tool. If the problem persists, disassemble the tool, clean and lubricate internal parts.
High or excessive vibration	High air pressure.	Ensure that the air pressure is correct at 90psi, max 100psi.
	Low air pressure 70-80psi can also cause high vibration.	Ensure that the air pressure is correct at 90psi, max 100psi.
	Lack of lubrication.	Lubricate with the recommended air tool oil daily.
	Worn bearings	Disassemble and inspect bearings. Grease or replace as needed.
Severe air leakage (note: minimal air leakage is often normal for air tools)	Air vave obstructed or damaged	Clean or replace
	Housing loose or damaged	Tighten or replace as needed
Tool generates excessive heat	Lack of lubrication.	Lubricate with the recommended air tool oil daily.

EXPLODED VIEW - 4" ANGLE GRINDER

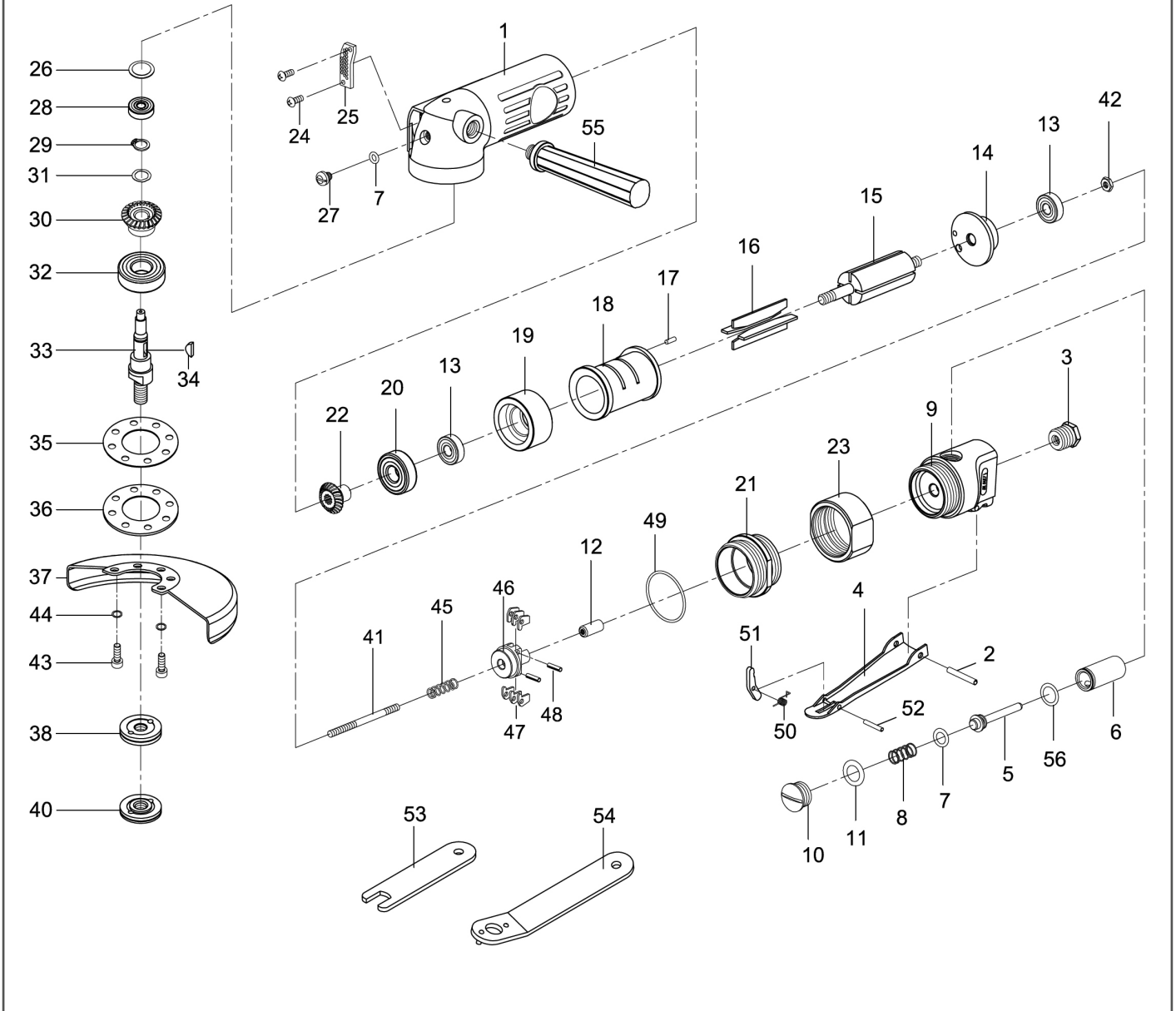

PARTS LIST - 4" ANGLE GRINDER

ITEM	PART NO.	DESCRIPTION	QTY	ITEM	PART NO.	DESCRIPTION	QTY
1	570.4001	Motor Housing	1	29	570.4029	Retaining Ring	1
2	570.4002	Spring Pin	1	30	570.4030	Bevel Gear	1
3	570.4003	Air Inlet	1	31	570.4031	Wave Washer	1
4	570.4004	Throttle Lever	1	32	570.4032	Ball Bearing	1
5	570.4005	Valve Stem	1	33	570.4033	Spindle M10 X1.5	1
6	570.4006	Bushing	1	34	570.4034	Key	1
7	570.4007	O-Ring	2	35	570.4035	Gasket	1
8	570.4008	Valve Spring	1	36	570.4036	Retainer	1
9	570.4009	Throttle Valve Housing	1	37	570.4037	Dis Cover	1
10	570.4010	Throttle Lever Plug	1	38	570.4038	Flange M10 X1.5	1
11	570.4011	O-Ring	1	40	570.4040	Flange Nut	1
12	570.4012	Plunger	1	41	570.4041	Adjust Screw	1
13	570.4013	Ball Bearing	2	42	570.4042	Adjust Nut	4
14	570.4014	End Plate	1	43	570.4043	Cap Screw (M5x16) [4]	4
15	570.4015	Rotor	1	44	570.4044	Spring Washer (M5) [4]	1
16	570.4016	Rotor Blades	4	45	570.4045	Spring	1
17	570.4017	Spring Pin	1	46	570.4046	Governor	6
18	570.4018	Cylinder	1	47	570.4047	Pendulum [6]	2
19	570.4019	Front Plate	1	48	570.4048	Spring Pin (3x12) [2]	1
20	570.4020	Ball Bearing	1	49	570.4049	O-Ring (37.8x1.78)	1
21	570.4021	Lock Nut	1	50	570.4050	Torsion Spring	1
22	570.4022	Bevel Pinion	1	51	570.4051	Throttle Lever Lock	1
23	570.4023	Coupling Nut	1	52	570.4052	Spring Pin (3x18)	1
24	570.4024	Screw	2	53	570.4053	Spanner	1
25	570.4025	Deflector	1	54	570.4054	Pin Wrench	1
26	570.4026	Spacer	1	55	570.4055	Handle	1
28	570.4027	Screw	1	56	570.4056	O-Ring (10.5x1)	1
28	570.4028	Ball Bearing	1				
ITEMS NOT SHOWN							
N/A	491.4050	4" Grinding Disc - 5 Pack	1	N/A	851.4060	75mm Twist Knot Wire Brush	1

TECHNICAL SPECIFICATIONS

DETAIL	4" Angle Grinder	Angle Grinder c/w Wire Brush
Part Code	170.4050	170.4150
Description	4" Angle Grinder	Angle Grinder c/w Wire Brush Head
Max Wheel Size	4" - 100mm	75mm Wire Brush
Spindle Diameter	M10	M10
Motor Power	0.75 HP	0.75 HP
No Load Speed	12,000 RPM	12,000 RPM
Air Hose Diameter	3/8" - 10mm	3/8" - 10mm
Air Consumption	4.0 cfm	4.0 cfm
Air Pressure	6.2 bar - (90 psi)	6.2 bar - (90 psi)
Air Inlet	1/4" BSP	1/4" BSP
Weight	1.8kg	1.8kg
Noise Level L_{WA} dB (A)	82.9	82.9
Vibration Level m/s^2	5.1	5.1
Trelawny SPT Ltd operates a policy of continuous product development and refinement and therefore reserves the right to change technical specifications and product designs without giving prior notice.		

Noise Levels measured in accordance with:
EN ISO 15744: 2008
Vibration levels measured in accordance with:
EN ISO 28927-9:2012 and EN ISO 20643:2005

(k) ** Equals the factor of uncertainty, which allows for variations in measurement and production. Vibration Data figures are tri-axial, which gives the total vibration emission. Because of various factors, the range of vibration emission during intended use can vary. The vibration is dependent on the task, the operators grip, and feed force employed etc. NOTE: The above vibration levels were obtained from tri-axial measurements to comply with the requirements of "The Control of Vibration at Work Regulations 2005*" and the revisions to the (8662) now EN ISO 28927:2012 and EN ISO 20643:2005 series of standards. These values are at least 1.4 times larger than the values obtained from single axis measurements.

*Based on European Union Council Directive 2002/44/EC (Physical Agents (Vibration) Directive)

This equipment has been designed and produced in accordance with the following directive:
2006/42/EC Machinery Directive
and applicable harmonised standard; EN ISO 1 1148-4:2012

If your company has any problem with our products or would like to discuss the possibility of an improvement being made to them, then please do not hesitate to contact us. Your comments are both important and appreciated.

Trelawny tools are thoroughly tested under specified conditions in accordance with applicable internationally recognised standards. When a tool is used on site the conditions may not be the same as those used in our tests.

Trelawny Surface Preparation Technology operates a policy of continuous product development and refinement and therefore reserves the right to change technical specifications and product designs without giving prior notice.

All rights reserved. Any unauthorised use or copying of the contents or part thereof is prohibited. This applies to trademarks, model denominations, part numbers and drawings.

Use only genuine Trelawny consumables with this product. The use of non-Trelawny spare parts invalidates the warranty.

THE PERFECT FINISH
STARTS WITH
TRELAWNY



DEALER STAMP:



CONTACT US

Trelawny SPT Limited

Trelawny House, 13 Highdown Road, Sydenham Industrial Estate,
Leamington Spa, Warwickshire, CV31 1XT, United Kingdom

Telephone: +44 (0)1926 883781

Email: sales@trelawny.com

Website: www.trelawny.com

Manual Part Number:

735.7070 01

CERTIFIED
ISO 9001



0008